

MS-90LP+

MULTISTOMP

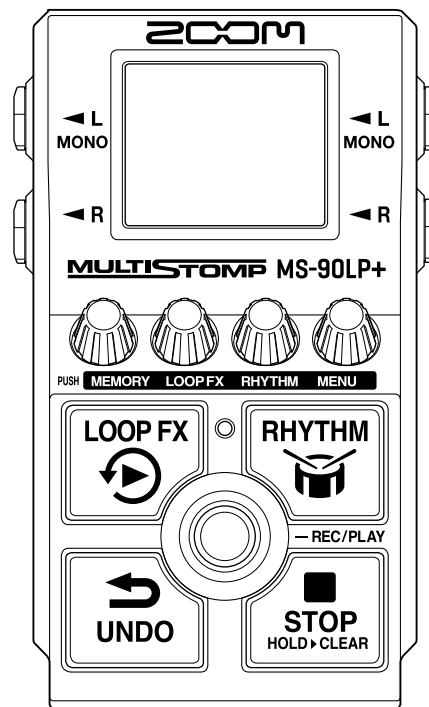

Operation Manual

You must read the Usage and Safety Precautions before use.

©2024 ZOOM CORPORATION

Copying or reprinting this manual in part or in whole without permission is prohibited.

Product names, registered trademarks and company names in this document are the property of their respective companies. All trademarks and registered trademarks in this document are for identification purposes only and are not intended to infringe on the copyrights of their respective owners.

Proper display is not possible on grayscale devices.

Notes about this Operation Manual

You might need this manual in the future. Always keep it in a place where you can access it easily. The contents of this document and the specifications of the product could be changed without notice.

- Microsoft and Windows are trademarks of the Microsoft group of companies.
- iPad, Mac, macOS and Lightning are trademarks of Apple Inc.
- iPhone is a trademark of Aiphone Co., Ltd. and is used under license.
- USB Type-C is a trademark of the USB Implementers Forum.
- The illustrations and display screens in this document could differ from the actual product.

Terms used in this manual

Memory

Memories, which can be easily recalled, store recorded phrases, looper and rhythm settings and effect selections. Phrases are saved and recalled in memories, and up to 100 of these can be saved.

AUTO SAVE

This function automatically saves recorded phrases, looper and rhythm setting changes and effect selections.

ECO MODE

This function will automatically turn the power off 10 hours after the last operation.

Contents

Notes about this Operation Manual.....	2
Terms used in this manual.....	3
MS-90LP+ overview.....	6
Looping with high audio quality.....	6
MS-90LP+ overview.....	9
Signal flow.....	9
Memory overview.....	11
Functions of parts.....	12
Top.....	12
Back.....	13
Overview of operation screens.....	14
Home Screen.....	14
MEMORY Screen.....	16
LOOP FX Screen.....	17
RHYTHM Screen.....	18
MENU Screen.....	19
Making connections.....	23
Turning the power on/off.....	24
Turning the power on.....	24
Turning the power off.....	27
Using the looper.....	28
Looper operations.....	29
Making looper settings.....	36
Using an effect during loop playback (LOOP FX Screen).....	39
Using rhythms (RHYTHM Screen).....	41
Starting/stopping rhythm playback.....	41
Selecting rhythm patterns (PATTERN).....	42
Rhythm patterns.....	43
Setting the rhythm tempo (BPM).....	44
Setting the rhythm volume (VOLUME).....	45
Switching memories.....	46
Managing memories.....	48
Saving memories (SAVE MEMORY).....	48
Copying memories (COPY MEMORY).....	50
Changing memory names (MEMORY NAME).....	52
Transferring files to and from a computer, smartphone or tablet.....	54
Connecting to computers, smartphones and tablets.....	54
MS-90LP+ folder and file structure.....	56
Disconnecting from computers, smartphones and tablets.....	57
Using MIDI devices.....	58

Other settings (MENU Screen)..... 60
 Looper settings..... 60
 Rhythm settings..... 63
 MIDI settings.....65
 Hardware settings..... 70
Managing the firmware.....78
 Checking the firmware version (VERSION)..... 78
 Updating the firmware..... 78
Restoring default settings (FACTORY RESET)..... 79
Checking the latest MS-90LP+ information (HELP)..... 80
Appendix..... 81
 Troubleshooting..... 81
Specifications.....82
MIDI implementation chart..... 84

MS-90LP+ overview

Looping with high audio quality

With a dual A/D converter circuit and support for 32-bit float WAV files, the MS-90LP+ enables looping with high audio quality.

Dual A/D converter circuit overview

The MS-90LP+ has two A/D converters with different input gains for one input circuit.

Providing amazing dynamic range

By combining two A/D converters, a wide dynamic range not possible with a single A/D converter has been realized.

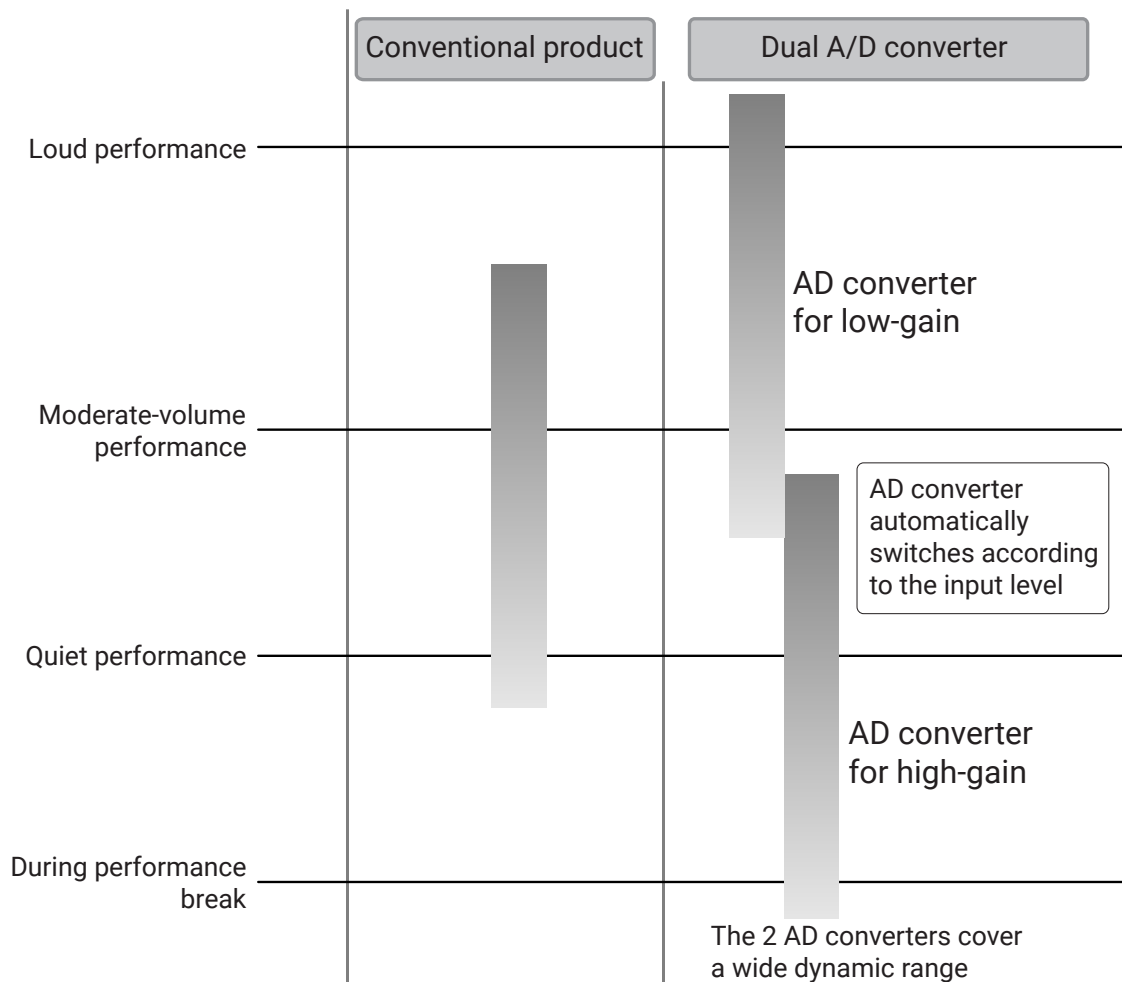

Switching between two A/D converters

The MS-90LP+ constantly monitors data from the two A/D converters, and automatically selects the one that provides the best input.

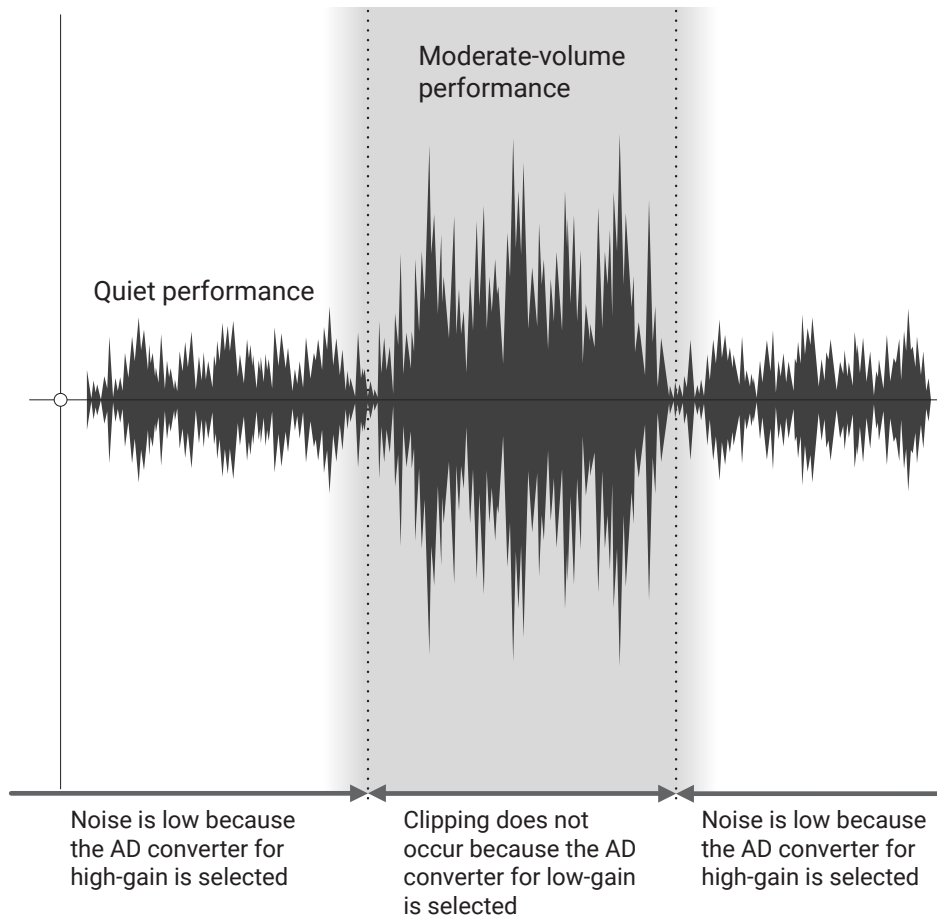

32-bit float WAV file overview

Phrases recorded by the MS-90LP+ are saved using 32-bit float WAV file format.

32-bit float WAV files have the following advantages over conventional 16/24-bit WAV files. These advantages allow the sound quality at the time of recording to be retained when the sound is adjusted.

Resolution advantage

32-bit float WAV files have the advantage of being able to maintain high resolution even if recorded at low levels. As a result, levels can be increased after recording without degrading the sound quality.

■ 16/24-bit WAV

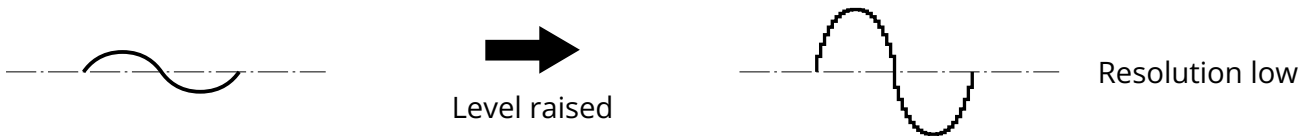

■ 32-bit float WAV



Clipping advantage

If a waveform sounds clipped when output from the MS-90LP+ with the level raised, the volume can be lowered to restore an unclipped waveform because the data in the 32-bit float WAV file itself is not clipped.

■ 16/24-bit WAV

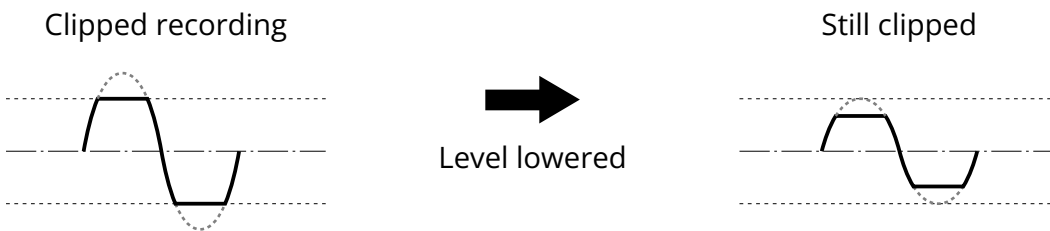

■ 32-bit float WAV

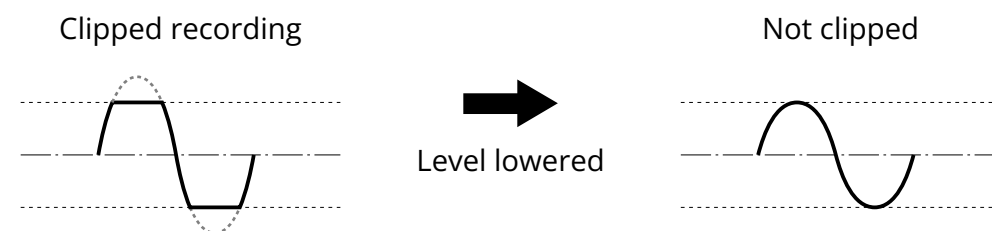

MS-90LP+ overview

Signal flow

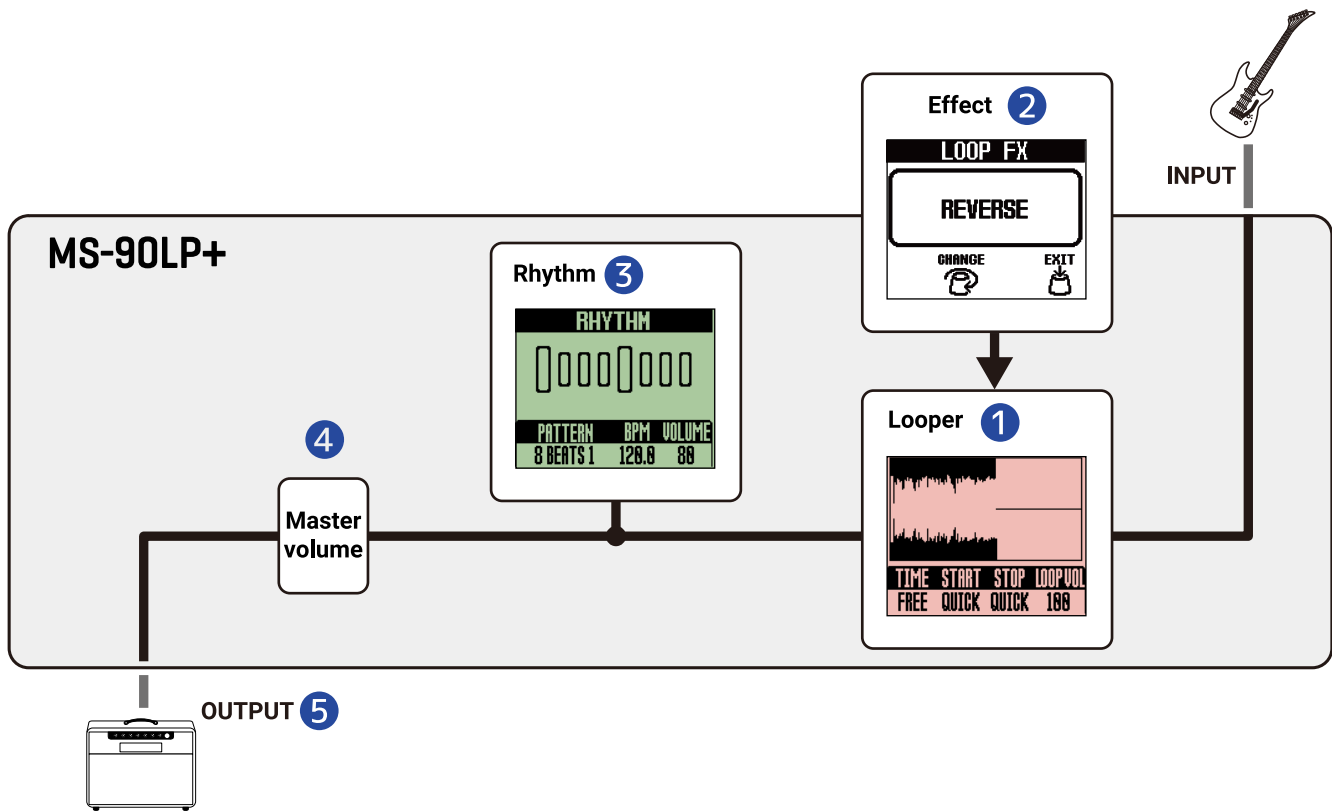

- 1 Looper**
Record phrases and loop their playback. (→ [Using the looper](#))
- 2 Effect**
An effect can be applied to loop playback. (→ [Using an effect during loop playback \(LOOP FX Screen\)](#))
- 3 Rhythm**
Rhythms can be played while recording phrases and during loop playback. (→ [Using rhythms \(RHYTHM Screen\)](#))
- 4 Master volume**
The overall volume can be adjusted. This setting is retained even when the memory is changed. (→ [Adjusting the overall output level \(OUTPUT VOLUME\)](#))
- 5 OUTPUT**
Connect an amp here.

HINT

Output from the guitar, looper and rhythm can be split as follows. (→ [Setting the output routing \(ROUTING\)](#))

- Rhythm sound output from the R jack (guitar and looper sound output from the L (MONO) jack)
 - Guitar sound output from the R jack (looper sound output from the L (MONO) jack, rhythm output in stereo)
-

Memory overview

Memories

These store recorded phrases, looper and rhythm settings and effect selections. Up to 100 memories can be used for saving and recall.

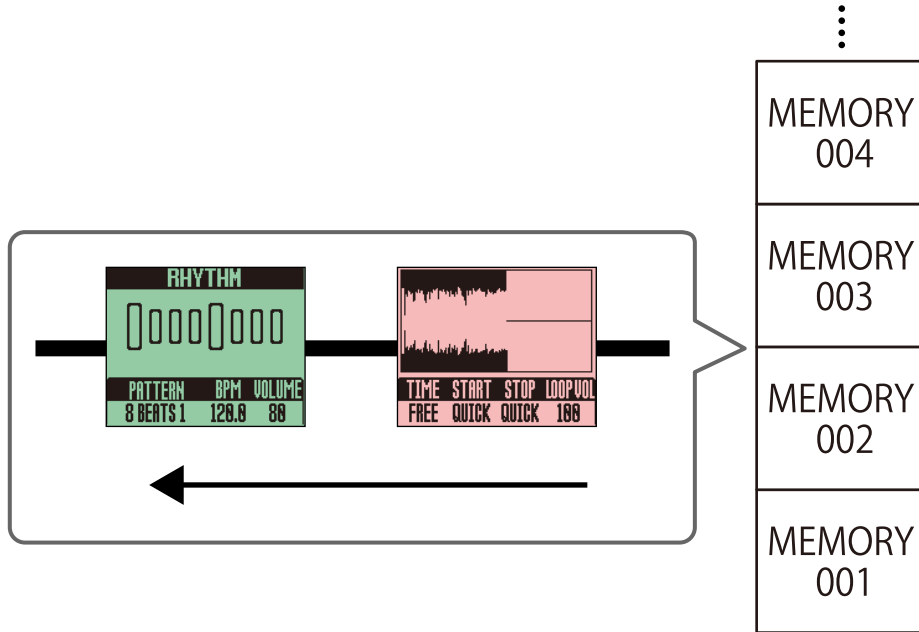

Functions of parts

Top

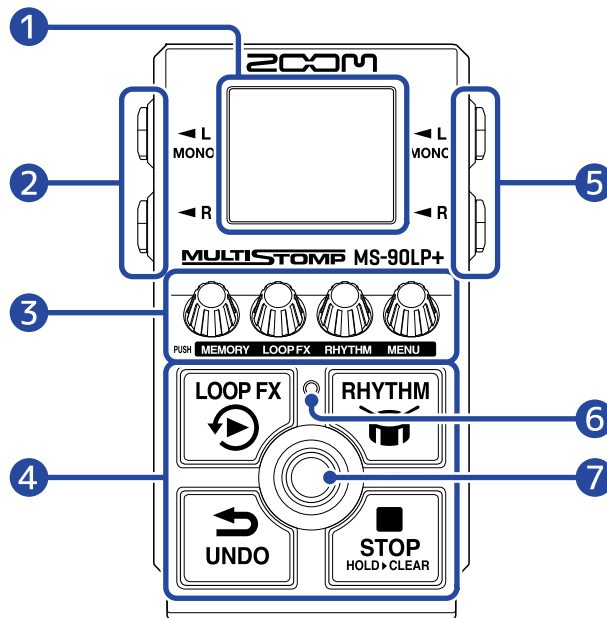

1 Display

This shows the looper status, parameter settings and other information.

2 Output jacks

Connect an amp or another effect here.
Use MONO for mono connections.

3 Parameter knobs

Use these to adjust parameters and make various settings.

4 Secondary footswitches

Use these to stop the looper, undo phrase recording, turn on/off the looper playback effect, and start/stop rhythm playback.

5 Input jacks

Connect a guitar, another instrument or an effect here.
Use MONO for mono connections.

6 Indicator

The blinking rate shows the tempo.

7 Footswitch

Use this for looper recording and playback operations.

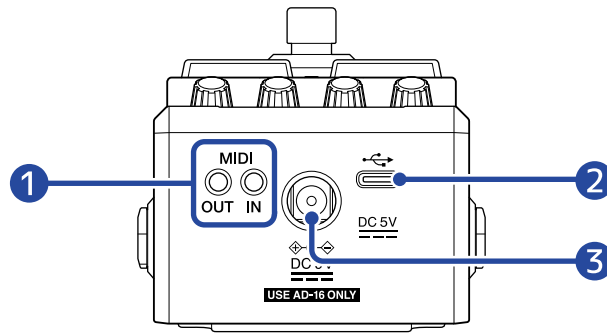

1 MIDI jacks

Use 3.5mm TRS cables to connect MIDI devices.

To connect MIDI devices with 5-pin DIN connectors, use 5-pin DIN-TRS MIDI (Type-A) conversion cables. By connecting MIDI devices, the MS-90LP+ can be controlled as well as be synchronized with other equipment.

2 USB (Type-C) port

The following operations are possible when connected to a computer, smartphone or tablet.

- Back up memories
- Import loop sound sources
- Control the MS-90LP+ using its MIDI functions

This supports operation on USB bus power.

3 DC 9V AC adapter connector

Connect a dedicated AC adapter (ZOOM AD-16) here.

Overview of operation screens

This section explains the screens that appear on the MS-90LP+ and the operations available on them.

Home Screen

This opens when the power is turned on.

The selected memory is shown, phrases can be recorded, played and stopped, and looper settings can be made on the screen.



1 Selected memory number

2 Memory name

"Empty" will appear if no phrase has been recorded yet.

3 Looper settings

The recording time, playback start/stop modes and volume of the looper can be set. (→ [Making looper settings](#))

■ The display color changes according to the looper status.





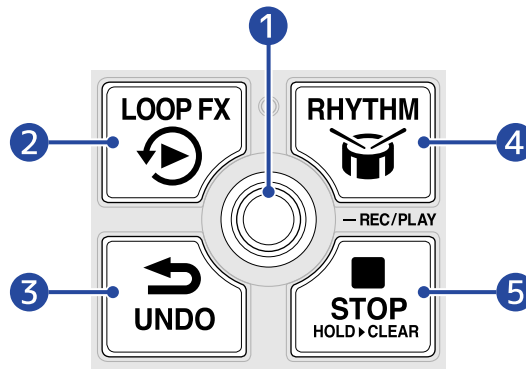



- Red: Phrase being recorded/overdubbed
- Green: Loop playing back
- Pale green: After a playback stop operation, playback is about to stop according to the stop setting
- Purple: Effect is on (during phrase recording)
- Blue: Effect is on (during loop playback)

- The footswitches have the following functions when the Home Screen is open.



- 1 Record/play phrases**
Overdubbing is also possible by pressing this during playback. (→ [Looper operations](#))
- 2 Turn the effect on/off**
The effect can be turned on/off during loop playback and recording. (→ [Using an effect during loop playback \(LOOP FX Screen\)](#))
- 3 Erase the last overdubbed phrase (UNDO function)**
The UNDO function can also be reversed after using it (REDO function). (→ [Erasing the last overdubbed phrase \(UNDO function\)](#), [Restoring an undone overdub \(REDO function\)](#))
- 4 Start/stop rhythm playback**
When a rhythm is being played, the indicator blinks in time with the tempo. (→ [Using rhythms \(RHYTHM Screen\)](#))
- 5 Stop loop recording/playback**
Press and hold this when stopped to clear the phrase. (→ [Stopping playback](#))

Opening the Home Screen

- If the [MEMORY Screen](#) is open, press the  (MENU) knob.
- If the [LOOP FX Screen](#) is open, press the  (MENU) knob.
- If the [RHYTHM Screen](#) is open, press one of the  (MEMORY),  (LOOP FX),  (RHYTHM) or  (MENU) knobs.
- If the [MENU Screen](#) is open, press the  (MEMORY) or  (MEMORY) knob to reopen the [Home Screen](#).

MEMORY Screen



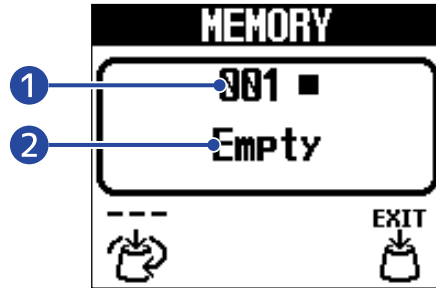

When the [Home Screen](#) is open, press the  (MEMORY) knob to open this screen where memories can be selected.



1 Selected memory

2 Memory name



“Empty” will appear if no phrase has been recorded yet.

- Turn the  (MEMORY) knob to select memories.
- If a memory with a recorded phrase is selected, the  (selection) icon will change to the  (play/stop/selection) icon. Press the  (MEMORY) knob to start/stop the playback of the selected memory.

Closing the MEMORY Screen

Press  (MENU) knob to confirm the selected memory and reopen the [Home Screen](#).

HINT



Pressing the  (LOOP FX) or  (RHYTHM) knob will also reopen the [Home Screen](#).

LOOP FX Screen

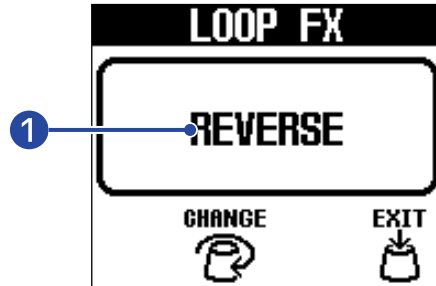
When the [Home Screen](#) is open, press the  (LOOP FX) knob to open this screen where an effect can be selected for use on loop playback.





1 Selected effect

- The **CHANGE**  (LOOP FX) knob can be turned to select the effect.
- During loop playback, press the  (LOOP FX) switch to turn on/off the selected effect. (When on, the screen will become blue.)
- During loop recording, pressing the  (LOOP FX) switch will put the selected effect into standby so that it will turn on during playback.

Closing the LOOP FX Screen

Press  (MENU) knob to confirm the selected effect and reopen the [Home Screen](#).

HINT

Pressing one of the  (MEMORY),  (LOOP FX) or  (RHYTHM) knobs will also reopen the [Home Screen](#).

RHYTHM Screen

When the [Home Screen](#) is open, press the  (RHYTHM) knob to open this screen where a rhythm pattern can be selected and its tempo and volume can be adjusted.

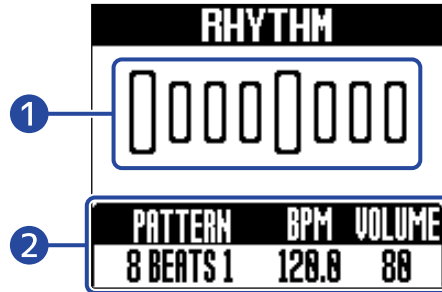

1 Rhythm pattern





An animation of the selected rhythm pattern is shown during rhythm playback.

2 Rhythm settings

The rhythm pattern can be selected and its tempo and volume can be adjusted.

- Press the  (RHYTHM) switch to start/stop rhythm playback.
- During rhythm playback, the indicator blinks in time with the tempo.

Closing the RHYTHM Screen

Press one of the  (MEMORY),  (LOOP FX),  (RHYTHM) or  (MENU) knobs to confirm the rhythm settings and reopen the [Home Screen](#).

MENU Screen

Various MS-90LP+ settings can be made on the screen.

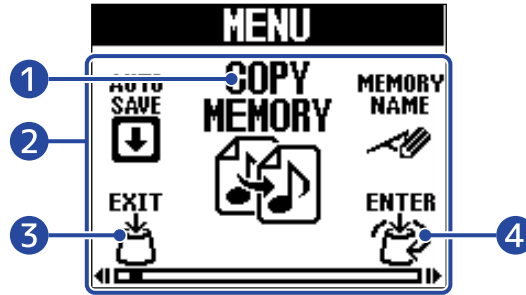

1 Selected setting item

The selected setting item is shown larger in the middle.

2 Setting items

Setting items are shown with icons. Turn the  (MENU) knob to select them.

3 (MEMORY) knob

This reopens the [Home Screen](#).

4 (MENU) knob

This shows the selected setting item.

Using the MENU Screen





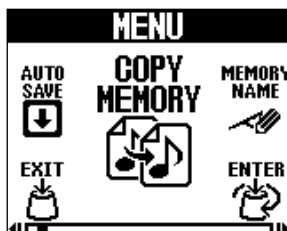

1. Press the  (MENU) knob to open the MENU Screen.





2. Turn the **ENTER** (MENU) knob to show the icon for the desired setting item.

Please see the linked reference sections for details about each setting.

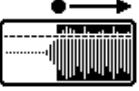

■ Memory management

<p>AUTO SAVE Set the automatic saving function. (→ Setting the automatic saving function (AUTO SAVE))</p> 	<p>COPY MEMORY Copy the memory. (This only appears when the automatic saving function is set to “SETTING & PHRASE”.) (→ Copying memories (COPY MEMORY))</p> 
<p>SAVE MEMORY Save the memory. (This only appears when the automatic saving function is set to “OFF” or “SETTING ONLY”.) (→ Saving memories (SAVE MEMORY))</p> 	<p>MEMORY NAME Set the memory name. (→ Changing memory names (MEMORY NAME))</p> 

■ Looper settings













<p>AUTO REC Set the automatic recording function. (→ Turning automatic recording on/off (AUTO REC))</p> 	<p>FADE TIME Set the fade in/out time. (→ Setting the fade in/out time (FADE TIME))</p> 
<p>REC MODE Select the operation that occurs after the first phrase completes recording. (→ Selecting the operation that occurs after the first phrase recording completes (REC MODE))</p> 	

■ Rhythm settings

<p>RHYTHM SYNC Set whether the looper is synchronized to the rhythm. (→ Rhythms can be synchronized with the looper (RHYTHM SYNC))</p> 	<p>PRE-COUNT Turn the pre-count on/off. (→ Setting the precount (PRECOUNT))</p> 
---	--

■ Hardware settings

<p>ROUTING Set the output routing. (→ Setting the output routing (ROUTING))</p> 	<p>OUTPUT VOLUME Adjust the overall output level. (→ Adjusting the overall output level (OUTPUT VOLUME))</p> 
--	---

	<p>Set the channel used to receive MIDI. (→ Setting the channel used to receive MIDI (MIDI RX CH))</p>		<p>Set the channel used to send MIDI. (→ Setting the channel used to send MIDI (MIDI TX CH))</p>
	<p>Turn on/off the MIDI clock output function. (→ Outputting MIDI clock (MIDI CLOCK OUT))</p>		<p>Turn on/off the MIDI program change output function. (→ Outputting program change messages (PROGRAM CHANGE OUT))</p>
	<p>Set which connectors thru output MIDI data when it is received through the MIDI IN and USB connectors. (→ Setting MIDI output (MIDI THRU))</p>		<p>Set the type of batteries used. (→ Setting the battery type (BATTERY TYPE))</p>
	<p>Adjust the backlight brightness. (→ Adjusting the backlight brightness (BACKLIGHT))</p>		<p>Adjust the display contrast. (→ Adjusting the display contrast (CONTRAST))</p>
	<p>Turn the ECO MODE on/off. (→ Setting the ECO MODE)</p>		<p>Transfer files to and from a computer, smartphone or tablet. (→ Transferring files to and from a computer, smartphone or tablet)</p>
	<p>Restore settings to their factory defaults. (→ Restoring default settings (FACTORY RESET))</p>		<p>Check the firmware version. (→ Checking the firmware version (VERSION))</p>
	<p>Show a 2D code for checking MS-90LP+ operation procedures. (→ Checking the latest MS-90LP+ information (HELP))</p>		

3. Press the  (MENU) knob.

This opens the selected setting screen.
(This example is when “PRECOUNT” is selected.)

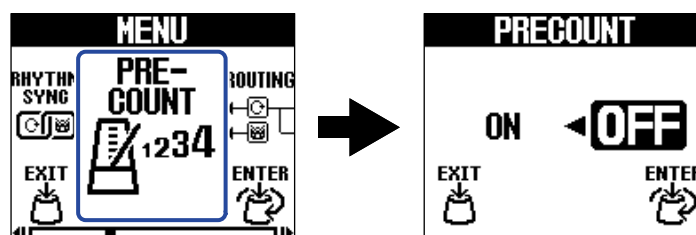

4. Turn the  (MENU) knob to select a setting.

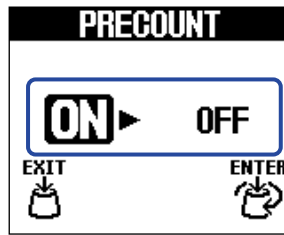



5. Press the  (MENU) knob.

This confirms the setting.

HINT

When a setting screen is open, press the  (MEMORY) knob to return to the [Home Screen](#) or [MENU Screen](#).

- When the  (EXIT) icon appears at the bottom left of the screen, this opens the [Home Screen](#).
 - When the  (BACK) icon appears at the bottom left of the screen, this opens the [MENU Screen](#).
-

Making connections

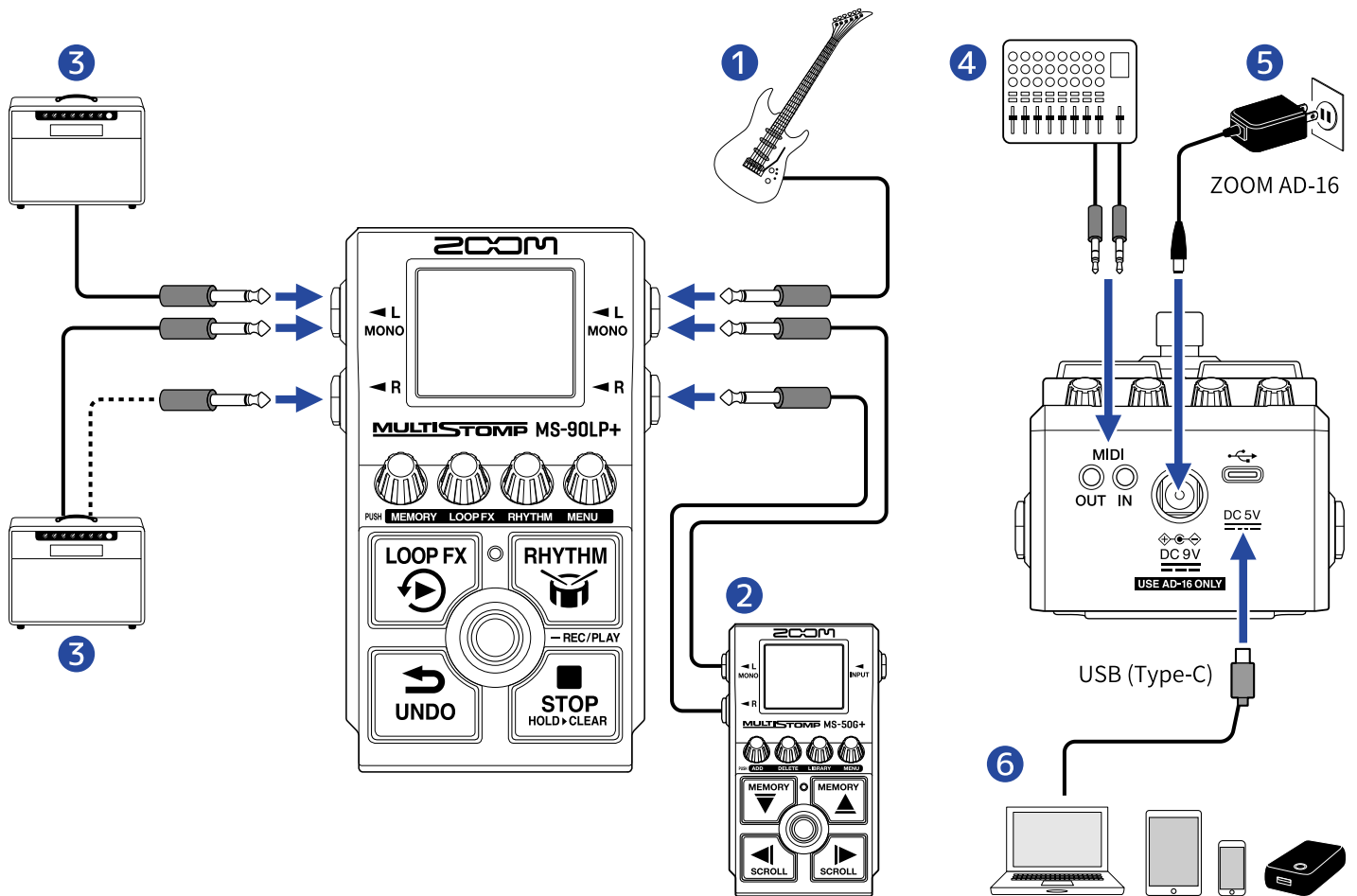

- 1 Guitar
- 2 Effect
- 3 Guitar amp
- 4 Drum machine or another MIDI device
- 5 AC adapter (ZOOM AD-16)
- 6 Computer (Mac/Windows), iPhone/iPad or portable battery

Connect with a USB cable (Type-C).

This can be used to back up memories, import loop audio sources, and transmit and receive MIDI over USB, for example.

Turning the power on/off

Turning the power on

1. Minimize the volume of the amp.

NOTE

To prevent noise and malfunction, connect an amp before turning the power on.

2. Provide power.

■ Using batteries

Open the cover on the bottom and install batteries into the battery compartment.

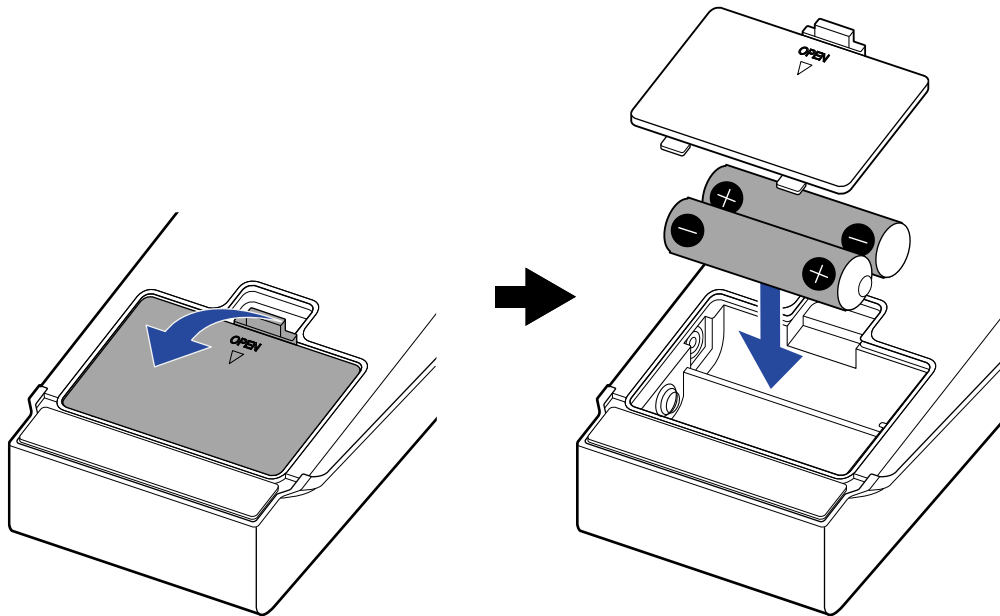

NOTE

- Use only one type of battery (alkaline, NiMH or lithium) at a time.
- Set the type of battery used correctly so that the amount of remaining battery charge can be monitored accurately. (→ [Setting the battery type \(BATTERY TYPE\)](#))
- If a "LOW BATTERY" message appears, replace the batteries or connect an AC adapter or portable battery.

■ Using an AC adapter

Use a ZOOM AD-16 AC adapter, which is specified for this unit.

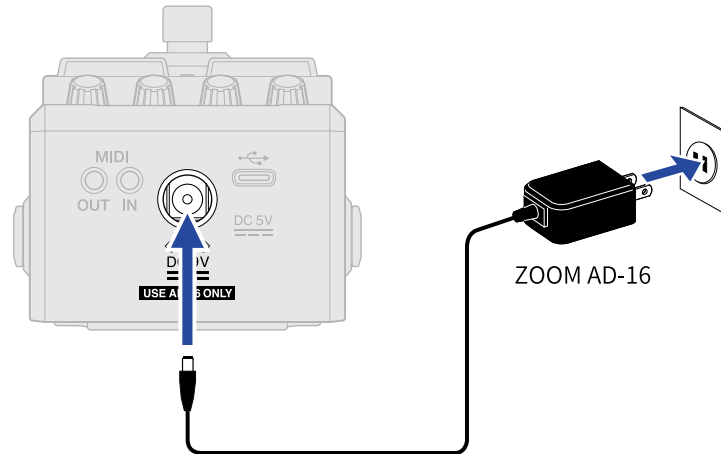

When an AC adapter is connected, the MS-90LP+ will power on.

■ Using a portable battery

Connect a portable battery.

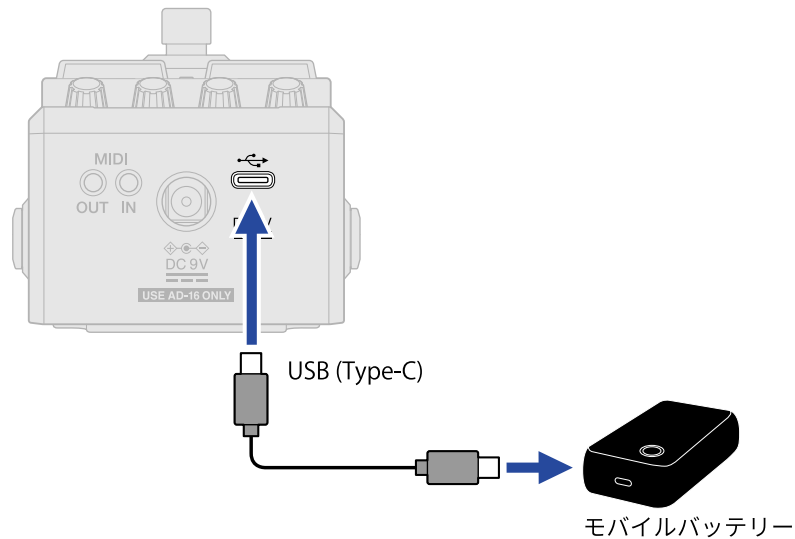

When a portable battery is connected, the MS-90LP+ will power on.

3. Connect a cable to an input jack.

When using batteries for power, connecting a cable to the L/MONO output jack will turn on the power. This turns on the MS-90LP+ power and opens the [Home Screen](#).



NOTE

When power is supplied by batteries, the power will not turn on when cables are connected to only the input jacks or the R output jack. Confirm that a cable is connected to the L/MONO output jack.

4. Raise the amp volume.

ECO MODE overview

- By default, ECO MODE is set to ON, so the power will automatically turn off if no use occurs for 10 hours.
- ECO MODE can also be turned OFF. (→ [Setting the ECO MODE](#))

Turning the power off

1. Minimize the volume of the amp.

2. Disconnect cables from the output jacks.

■ **If using batteries**

Disconnect the cable from the L/MONO output jack to turn off the display and the power.

■ **If using an AC adapter or portable battery**

Disconnect the AC adapter or portable battery to turn off the display and the power.

Using the looper

Played phrases can be recorded, and loop phrases up to 90 minutes long can be created.

Format of recorded files

Recorded phrases are saved as stereo files in the following format.

- File format: WAV
- Sample rate: 44.1 kHz
- Bit depth: 32-bit float

Helpful phrase recording function

While playing rhythms (→ [Using rhythms \(RHYTHM Screen\)](#)), quantization is enabled when recording phrases, so even if the recording ending time is not exact, the loop will automatically be adjusted so that loop playback stays in time.



Changing screens during phrase recording/playback

When the looper is recording or playing, it will continue doing so even if a different screen is opened.

Looper operations

This section explains basic looper operations.

Recording phrases

1. When the [Home Screen](#) is open, press the  (MEMORY) knob to open the [MEMORY Screen](#). Then, turn the  /  (MEMORY) knob to select the memory to use for recording a new phrase.

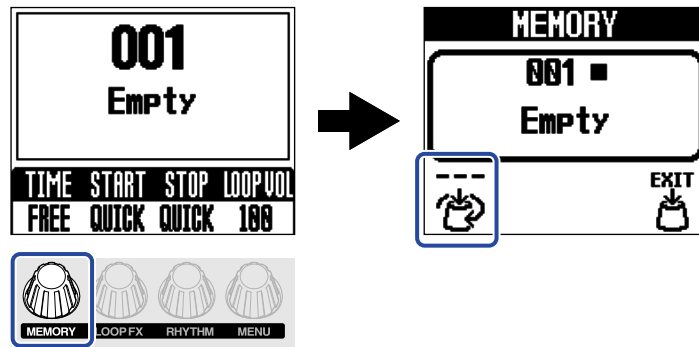

“Empty” will appear for memories that do not yet have phrases recorded.

If a memory already has a recorded phrase, sound can be added to it by overdubbing. (→ [Adding performances to recorded phrases \(overdubbing\)](#))

2. Press the  (MENU) knob to return to the [Home Screen](#).

3. Press the  (footswitch) to begin phrase recording.

The screen becomes red during recording.

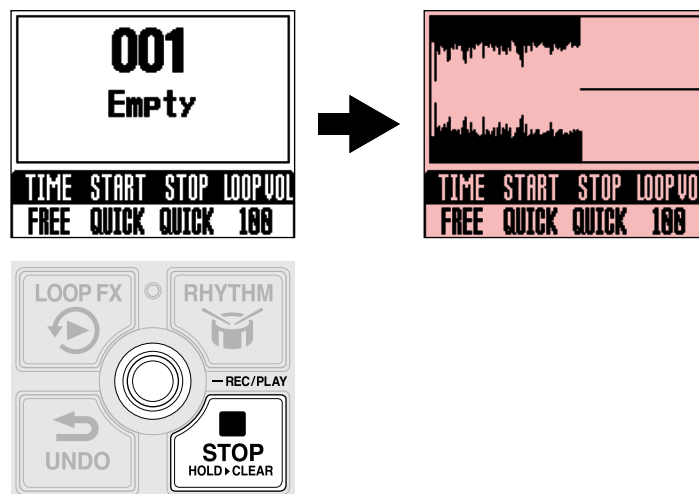

HINT

- By using the RHYTHM SYNC function, rhythm playback can be started at the same time recording starts.
(→ [Rhythms can be synchronized with the looper \(RHYTHM SYNC\)](#))
 - By using the AUTO REC function, phrase recording can be started simultaneously with a performance.
(→ [Turning automatic recording on/off \(AUTO REC\)](#))
-

Stopping recording and starting loop playback

1. When recording, press the  (footswitch) to stop recording.

The screen will become green and loop playback will start.

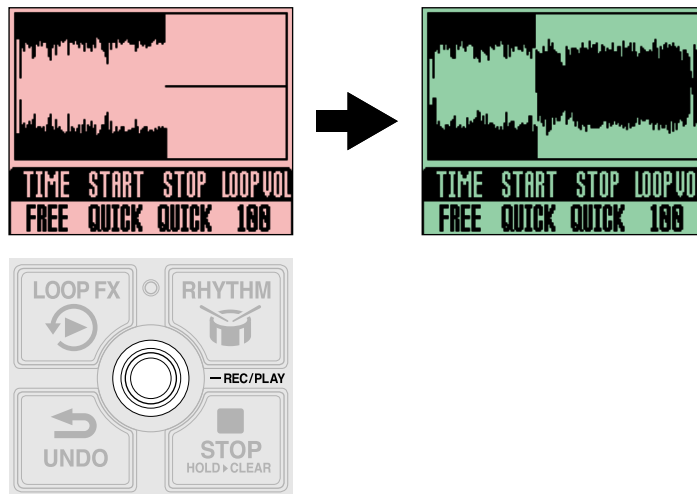

NOTE

- When the maximum recording time is reached, recording will stop and loop playback will start.
- If the recording time is set to “J×1-64”, recording will stop and loop playback will start after the set recording time has elapsed. (→ [Setting the recording time \(TIME\)](#))

HINT

- When recording, pressing the  (STOP) switch will stop recording (without starting loop playback).
- After recording the first phrase completes, overdubbing can also start automatically or recording can stop without starting playback. (→ [Selecting the operation that occurs after the first phrase recording completes \(REC MODE\)](#))

Stopping playback

1. Press the  (STOP) switch during playback.

The screen will become its original color and playback will stop.

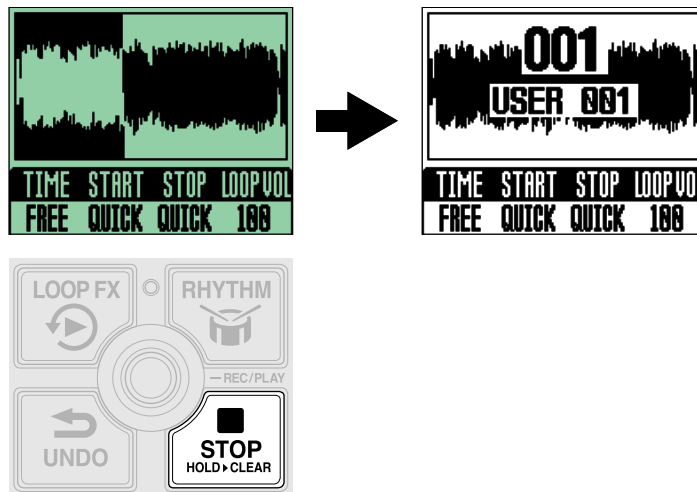

Once a phrase has been recorded, "USER 001" (001 is the memory number) or similar memory name will be shown.

NOTE

How stopping occurs when the  (STOP) switch is pressed can be changed. (→ [Setting the stop mode \(STOP\)](#))

Starting loop playback of the recorded phrase

1. When stopped, press the  (footswitch).

The screen will become green and loop playback will start.

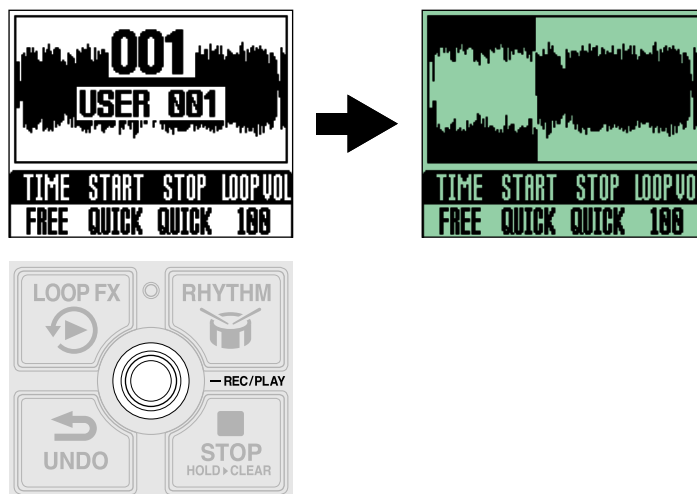

HINT

By turning on the RHYTHM SYNC function, rhythm playback can be started at the same time playback starts. (→ [Rhythms can be synchronized with the looper \(RHYTHM SYNC\)](#))

Adding performances to recorded phrases (overdubbing)

1. During playback, press the  (footswitch) to start overdubbing.

The screen becomes red during overdubbing.

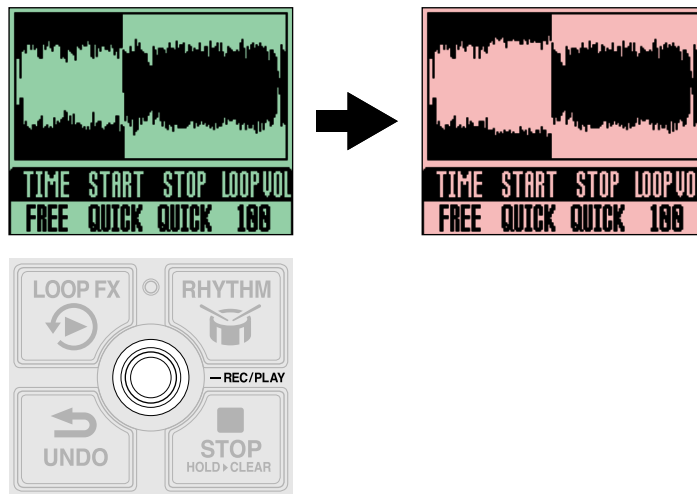

- When the end of the loop is reached, loop playback will continue from the beginning, and overdubbing can be repeated.
- When overdubbing, press the  (footswitch) to stop overdubbing, but continue loop playback.
- Overdubbing can be repeated any number of times.

HINT

After the first recording completes, overdubbing can also start automatically or recording can stop without starting playback. (→ [Selecting the operation that occurs after the first phrase recording completes \(REC MODE\)](#))

Erasing the last overdubbed phrase (UNDO function)

The most recently overdubbed phrase can be undone with a single operation.

1. Press the  (UNDO) switch during playback.

“UNDO” will appear and the most recently overdubbed phrase will be erased.

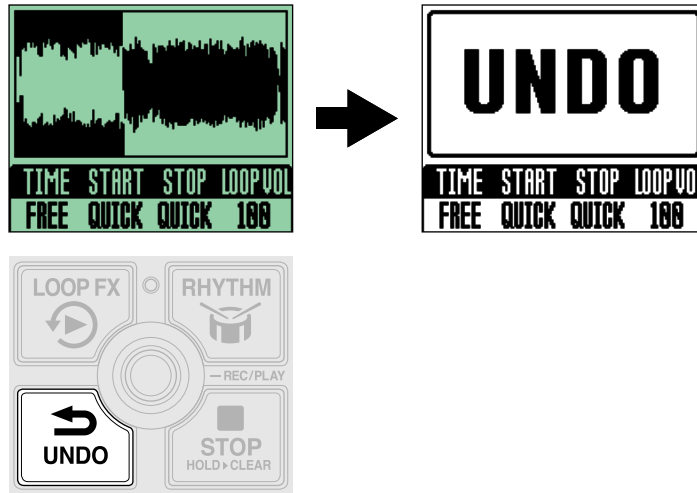

Restoring an undone overdub (REDO function)

Erased phrases can also be restored with a single operation.

1. After undoing, press the  (UNDO) switch.

“REDO” will appear and the erased phrase will be restored.

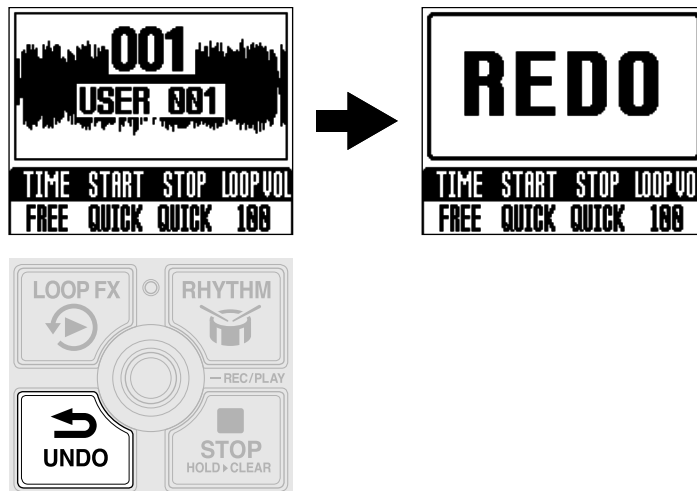

Clearing phrases

1. When stopped, press and hold the  (STOP) switch.

“CLEAR” will appear and the recorded phrase will be cleared.

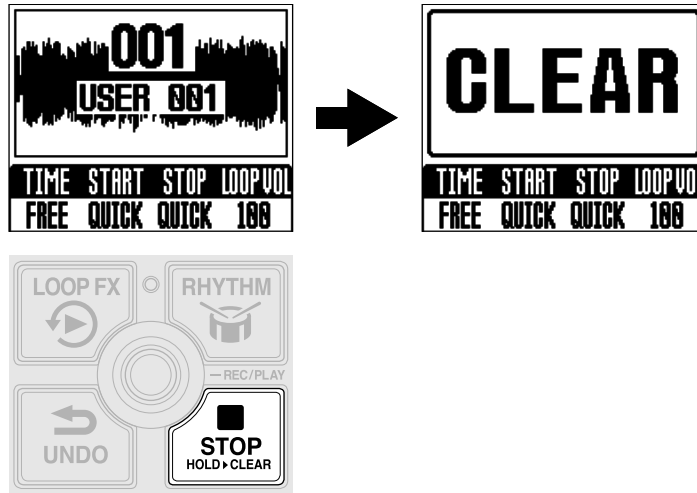

Making looper settings

This section explains various looper settings that can be made on the [Home Screen](#) (recording time, phrase playback starting/stopping and phrase playback volume).



For information about other detailed looper settings, see "[Looper settings](#)".

Setting the recording time (TIME)

The phrase recording time can be set.

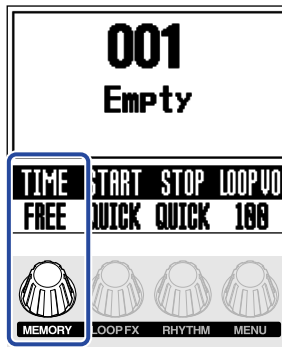
1. When the [Home Screen](#) is open, turn the  (MEMORY) knob to select a setting.



Setting	Explanation
FREE	Recording will continue until stopped using the  (footswitch) or  (STOP switch) or the maximum recording time (90 minutes) is reached.
J×1-64	When the set recording time is reached, recording will stop and loop playback will start. The actual recording time is determined as follows according to the BPM (tempo) setting. (→ Setting the rhythm tempo (BPM)) The recording time (seconds) = $60 \div \text{BPM} \times \text{quarter notes}$.

Setting the phrase playback start mode (START)

How loop playback starts can be set.

1. When the [Home Screen](#) is open, turn the  (LOOP FX) knob to select the playback start mode.



Setting	Explanation
QUICK	The loop will start playback immediately after a play operation.
FADE	Playback of the phrase will fade in.

Setting the stop mode (STOP)

How the looper behaves when playback is stopped can be set.

1. When the [Home Screen](#) is open, turn the  (RHYTHM) knob to select the stop mode.

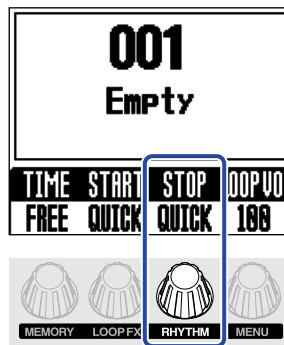

Setting	Explanation
QUICK	The loop will stop immediately after a stop operation.
END	The loop will stop after playing to its end.
FADE	The loop will stop after fading out.

HINT

When "END" or "FADE" is selected, the screen will become light green after the stop operation until playback stops.

Adjusting the looper volume (LOOP VOL)

The loop playback volume can be adjusted.

1. When the [Home Screen](#) is open, turn the  (MENU) knob to adjust the loop playback volume.

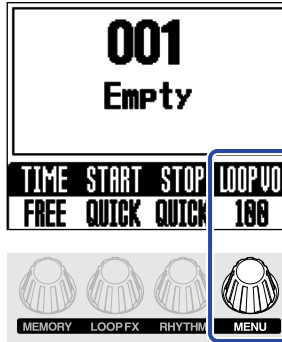

This adjusts the volume of the loop in the memory. To adjust the overall volume of the MS-90LP+ , see [“Adjusting the overall output level \(OUTPUT VOLUME\)”](#).

HINT

This can be set from 0 to 200.

Notes about the looper tempo

- The looper tempo is also used by rhythms.
- The tempo can also be set as explained in [“Setting the rhythm tempo \(BPM\)”](#).
- The tempo cannot be changed for memories that already have phrases recorded.

NOTE

If the rhythm precount function is on, recording will start after the precount. (→ [Setting the precount \(PRECOUNT\)](#))

HINT

- During rhythm playback (→ [Using rhythms \(RHYTHM Screen\)](#)), quantization is enabled so even if the recording ending time is not exact, the loop will automatically be adjusted so that loop playback stays in time.
 - The tempo can also be set by pressing the footswitch repeatedly with a steady interval (tap tempo). (→ [Using an effect during loop playback \(LOOP FX Screen\)](#))
-

Using an effect during loop playback (LOOP FX Screen)

Effects can be used during loop playback. These include reverse, half-speed and double-speed playback, as well as repeat playback of a short interval.

1. When the [Home Screen](#) is open, press the  (LOOP FX) knob to open the [LOOP FX Screen](#).

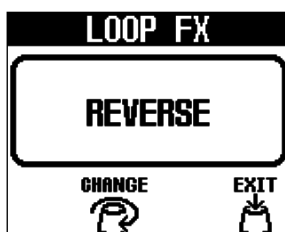

2. Turn the  (LOOP FX) knob to select an effect.

Effect name	Effect
REVERSE	The loop will be played backward.
HALF SPEED	The loop will be played at half speed.
DOUBLE SPEED	The loop will be played at double speed.
HOLD	A short interval will be played repeatedly.
TAPE STOP	Playback will slow down until it stops.
ONE-SHOT PLAY	The loop will play once and then stop.
RESTART	The loop will begin playing from the beginning.
TAP TEMPO	The tempo can be set by pressing the  (footswitch) repeatedly at the desired speed.

HINT

- REVERSE, HALF SPEED, DOUBLE SPEED and HOLD can also be set to be unlatched ("UNLATCH" will appear after the effect name). Unlatched effects are only turned on while the  (LOOP FX) switch is being pressed.
- When using an imported loop sound source, REVERSE can only be used if the following conditions are met. (→[Transferring files to and from a computer, smartphone or tablet](#))
 - File format: WAV (stereo)
 - Sample rate: 44.1 kHz
 - Bit depth: 32-bit float

3. Press the  (MENU) knob to return to the [Home Screen](#).

4. During loop playback, press the  (LOOP FX) switch to turn the effect on/off.
When on, the screen will become blue.

HINT

- When one of the following effects is selected, pressing the  (LOOP FX) switch during loop recording will put the selected effect into standby so that it will turn on during playback. (The screen will become purple.)
REVERSE, HALF SPEED, DOUBLE SPEED, HOLD
 - Effects can also be turned on/off on the [LOOP FX Screen](#).
-

Using rhythms (RHYTHM Screen)

Phrases can be recorded and loops played along with the built-in rhythms.

Starting/stopping rhythm playback

1. Press the  (RHYTHM) switch when the [Home Screen](#) or [RHYTHM Screen](#) is open. Rhythm playback will start and the indicator will blink in time with the tempo.

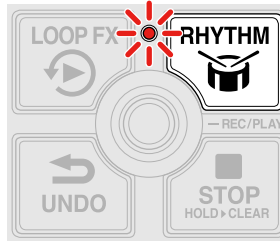

If the  (RHYTHM) switch is pressed when the [RHYTHM Screen](#) is open, an animation of the pattern will be shown as the rhythm is played.

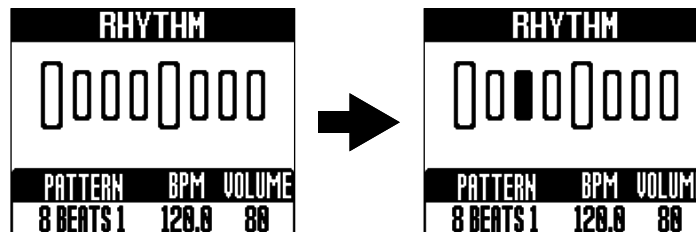

When a rhythm is playing, pressing the  (RHYTHM) switch will stop rhythm playback.

Selecting rhythm patterns (PATTERN)

1. Press the  (RHYTHM) knob to open the [RHYTHM Screen](#), and turn the  (MEMORY) knob to select a rhythm pattern.

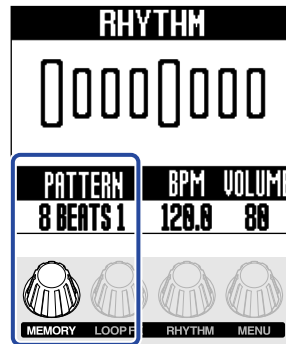

See "[Rhythm patterns](#)" for information about the rhythm pattern types.

HINT

Rhythm patterns can be selected during rhythm playback. (→ [Starting/stopping rhythm playback](#))

Rhythm patterns

No.	Pattern Name	Time Sig.	No.	Pattern Name	Time Sig.	No.	Pattern Name	Time Sig.
1	8 BEATS 1	4/4	24	SHUFFLE 1	4/4	47	LO-FI HH 1	4/4
2	8 BEATS 2	4/4	25	SHUFFLE 2	4/4	48	LO-FI HH 2	4/4
3	8 BEATS 3	4/4	26	SHUFFLE 3	4/4	49	NU JAZZ 1	4/4
4	8 BEATS 4	4/4	27	SHUFFLE 4	4/4	50	NU JAZZ 2	4/4
5	16 BEATS 1	4/4	28	BOSSA 1	4/4	51	HOUSE 1	4/4
6	16 BEATS 2	4/4	29	BOSSA 2	4/4	52	HOUSE 2	4/4
7	FUNK 1	4/4	30	CAJON 1	4/4	53	TECHNO 1	4/4
8	FUNK 2	4/4	31	CAJON 2	4/4	54	TECHNO 2	4/4
9	FUSION	4/4	32	CAJON 3	4/4	55	DANCE HALL	4/4
10	JAZZ FUNK 1	4/4	33	CAJON 4	4/4	56	TRIPLET	4/4
11	JAZZ FUNK 2	4/4	34	SAMBA 1	4/4	57	JAZZ WALTZ 1	3/4
12	POP 80S 1	4/4	35	SAMBA 2	4/4	58	JAZZ WALTZ 2	3/4
13	POP 80S 2	4/4	36	SAMBA 3	4/4	59	CT WALTZ 1	3/4
14	MOTOWN	4/4	37	SALSA 1	4/4	60	CT WALTZ 2	3/4
15	DISCO	4/4	38	SALSA 2	4/4	61	5/4 GROOVE 1	5/4
16	JAZZ 1	4/4	39	CUBA GROOVE 1	4/4	62	5/4 GROOVE 2	5/4
17	JAZZ 2	4/4	40	CUBA GROOVE 2	4/4	63	METRONOME	
18	JAZZ 3	4/4	41	DJEMBE 1	4/4	64	METRONOME 3	3/4
19	JAZZ 4	4/4	42	DJEMBE 2	4/4	65	METRONOME 4	4/4
20	COUNTRY 1	2/4	43	REGGAE 1	4/4	66	METRONOME 5	5/4
21	COUNTRY 2	2/4	44	REGGAE 2	4/4	67	GUIDE 1	4/4
22	BLUES 1	4/4	45	NU SOUL 1	4/4	68	GUIDE 2	4/4
23	BLUES 2	4/4	46	NU SOUL 2	4/4			

Setting the rhythm tempo (BPM)

1. Press the  (RHYTHM) knob to open the [RHYTHM Screen](#). Then, turn the  (RHYTHM) knob to set the tempo.

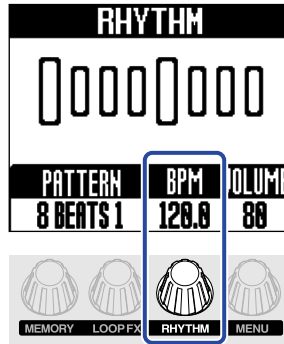

NOTE

The tempo cannot be changed for memories that already have phrases recorded.

HINT

- This can be set from 40 to 300.
- The tempo set here will be shared by the looper.
- The tempo can be set during rhythm playback. (→ [Starting/stopping rhythm playback](#))
- The tempo can also be set by pressing the footswitch repeatedly with a steady interval (tap tempo). (→ [Using an effect during loop playback \(LOOP FX Screen\)](#))

Setting the rhythm volume (VOLUME)

1. Press the  (RHYTHM) knob to open the [RHYTHM Screen](#), and turn the  (MENU) knob to set the rhythm volume.

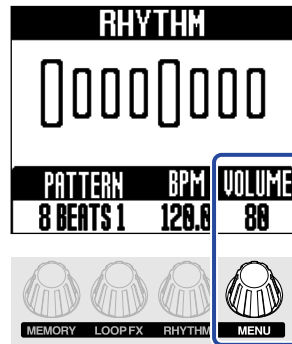

This adjusts the volume of the rhythm in the memory. To adjust the overall volume of the MS-90LP+ , see "[Adjusting the overall output level \(OUTPUT VOLUME\)](#)".

HINT

- This can be set from 0 to 100.
 - The rhythm volume can be set during rhythm playback. (→ [Starting/stopping rhythm playback](#))
-

Switching memories

The MS-90LP+ manages recorded phrases in memories. Looper and rhythm settings along with the selected effect are saved together in memories.

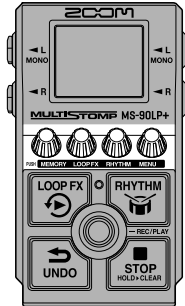

1. When the [Home Screen](#) is open, press the  (MEMORY) knob to open the [MEMORY Screen](#).

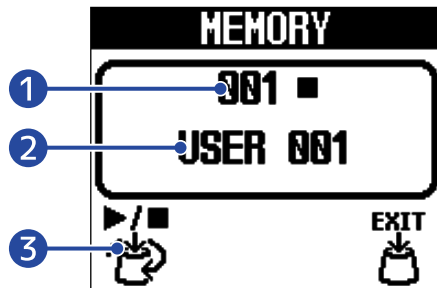

1 Memory number

This shows the number of the selected memory.

When the selected memory already has a recorded phrase, a play or stop icon will appear to the right of the memory number.

2 Memory name



This is the name of the selected memory.

“Empty” will appear if no phrase has been recorded yet.

Memory names can be changed. (→ [Changing memory names \(MEMORY NAME\)](#))

3 Memory selection icon

This icon changes depending on whether a phrase has been recorded.

-  (select) icon when no phrase recorded yet
-  (play/stop/select) icon when phrase already recorded (play/stop symbols added above select icon)

2. Turn the  (MEMORY) knob to select a memory.

If a phrase has already been recorded, the  (MEMORY) knob can be pressed to start/stop playback of the selected memory.

3. Press the  (MENU) knob.

This confirms the memory selection and reopens the [Home Screen](#).

NOTE

The following settings are saved in memories.

- Looper settings: TIME, START, STOP, LEVEL (looper), AUTO REC, FADE TIME, REC MODE
- Rhythm settings: PATTERN, BPM, LEVEL (rhythm), RHYTHM SYNC, PRECOUNT
- Other settings: LOOP FX, MEMORY NAME

HINT

100 memories are available (memory numbers 001–100).

Managing memories

Saving memories (SAVE MEMORY)

When the automatic saving function is set to "OFF" or "SETTING ONLY", manually save recorded phrases and settings as necessary.

"SETTING & PHRASE" is the default setting for the automatic saving function. Using this, recorded phrases and various settings will be saved automatically.

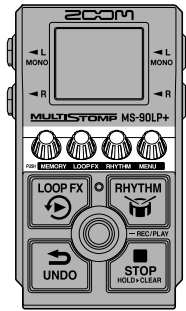

HINT

See "[Setting the automatic saving function \(AUTO SAVE\)](#)" for details about this function.

1. Press the  (MENU) knob to open the [MENU Screen](#).

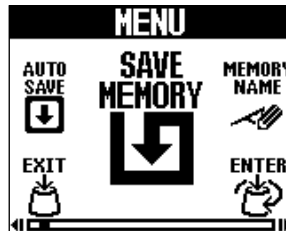

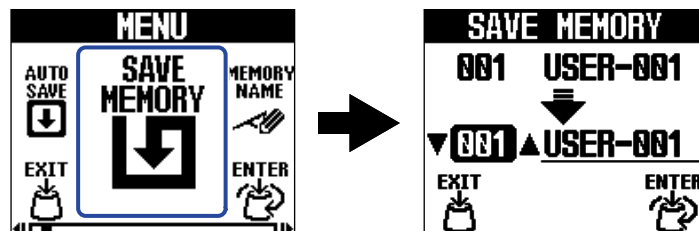

2. Turn the  (MENU) knob to select "SAVE MEMORY" and press the  (MENU) knob.

This opens the SAVE MEMORY Screen.



NOTE

The SAVE MEMORY Screen will not be shown when the AUTO SAVE function is set to "SETTING & PHRASE".

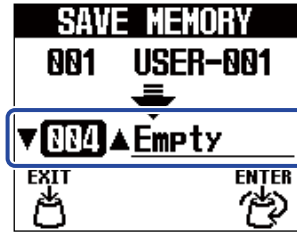

3. Turn the  (MENU) knob to select the memory save destination and press the  (MENU) knob.
- “Empty” is shown for memories that have nothing saved in them.

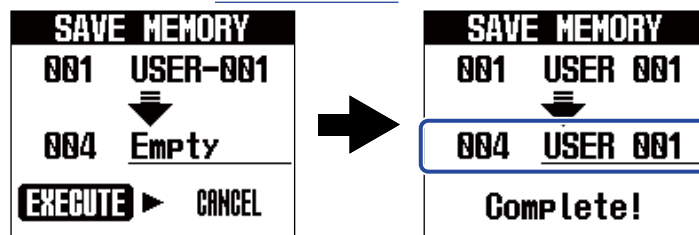

4. Press the  (MENU) knob.

This saves the memory and reopens the [Home Screen](#).



To cancel saving, turn the  (MENU) knob to select “CANCEL” and press the  (MENU) knob.



Copying memories (COPY MEMORY)

Memories can be copied to other locations.

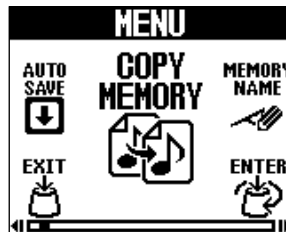

1. Press the  (MENU) knob to open the [MENU Screen](#).



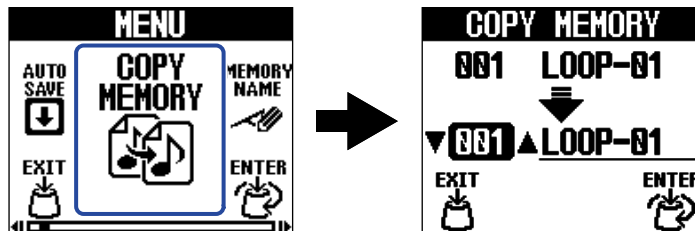

2. Turn the  (MENU) knob to select "COPY MEMORY" and press the  (MENU) knob.
This opens the COPY MEMORY Screen.



NOTE

The COPY MEMORY Screen will not be shown when the AUTO SAVE function is set to "OFF" or "SETTING ONLY". (→ [Setting the automatic saving function \(AUTO SAVE\)](#))

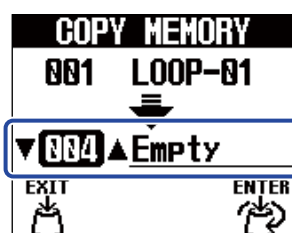

3. Turn the  (MENU) knob to select the memory copy destination and press the  (MENU) knob.
"Empty" is shown for memories that have nothing saved in them.



4. Press the  (MENU) knob.

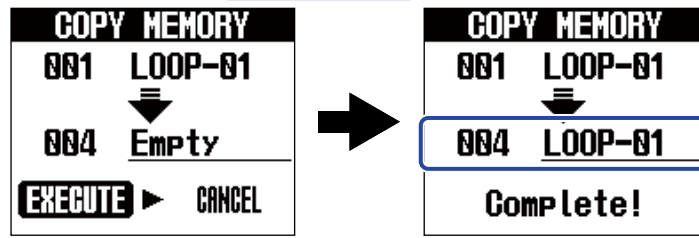

This copies the memory and reopens the [Home Screen](#).



To cancel copying, turn the  (MENU) knob to select "CANCEL" and press the  (MENU) knob.

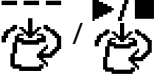

Changing memory names (MEMORY NAME)



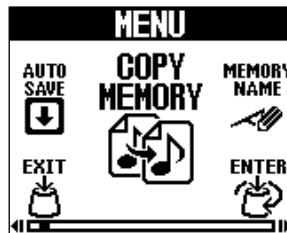

1. When the MEMORY Screen is open, turn the  /  (MEMORY) knob to select the memory to be renamed. Then, press the  (MENU) knob. (→ [Switching memories](#))

2. Press the  (MENU) knob to open the MENU Screen.

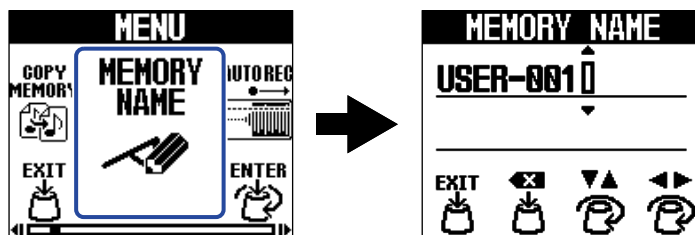

3. Turn the  (MENU) knob to select "MEMORY NAME" and press the  (MENU) knob. This opens the MEMORY NAME Screen.



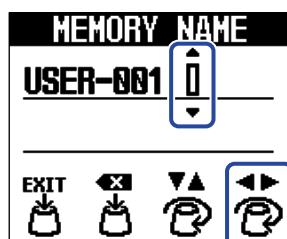

4. Turn the  (MENU) knob to move the cursor.

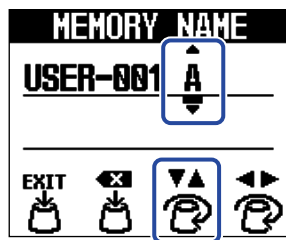

5. Turn the  (RHYTHM) knob to insert a character.



• Press the  (LOOP FX) knob to delete the character before the cursor.

• Press and hold the  (LOOP FX) knob to delete all the characters.

6. Press the  (MEMORY) knob.

This confirms the name and reopens the [Home Screen](#).

HINT

The characters and symbols that can be used are as follows.

! % & ' + , - . = _ (space) A-Z, a-z, 0-9

Transferring files to and from a computer, smartphone or tablet

By connecting the MS-90LP+ to a computer, smartphone or tablet, memories can be backed up, and loop sound sources can be imported, for example.

Connecting to computers, smartphones and tablets

1. Use a USB (Type-C) cable to connect the MS-90LP+ USB port to a computer, smartphone or tablet.

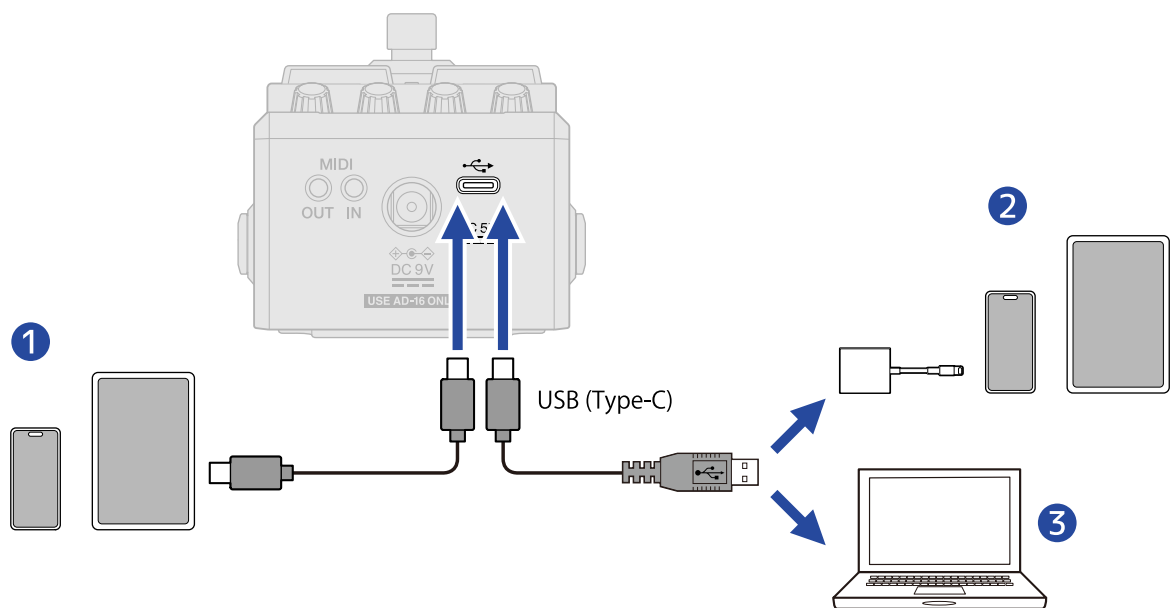

- 1 Smartphone/tablet (USB Type-C)
- 2 iPhone/iPad (Lightning)
- 3 Computer (Windows/Mac)

NOTE

- Use a USB cable that supports data transfer.
- Use a Lightning to USB 3 Camera Adapter to connect to an iPhone/iPad with a lightning connector.
- When using this with a smartphone or tablet, connect an AC adapter to provide power. (→ [Turning the power on](#))

2. Select "FILE TRANSFER" on the [MENU Screen](#).

The FILE TRANSFER Screen will open, showing that the MS-90LP+ is in file transfer mode.

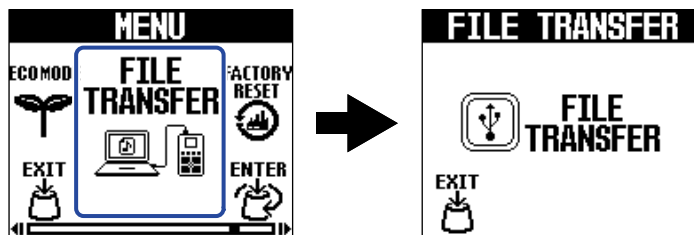

When in file transfer mode, operations on the MS-90LP+ are disabled.

3. Use the computer to work with the files saved on the MS-90LP+.

- Backing up memories: The data for the memories are saved in the "001" – "100" folders. Save them on the computer as necessary.
- Importing loop audio: Copy audio files to be used as loops into the "001" – "100" folders.

NOTE

- Audio files must be as follows to import them as loop sources.
 - File format: WAV (stereo/mono)
 - Sample rate: 44.1 kHz
 - Bit depth: 16, 24 or 32 (float)
- The REVERSE effect can only be used with memories that have imported WAV files if they are stereo and have a 32-bit float bit depth. (→[Using an effect during loop playback \(LOOP FX Screen\)](#))
- If a folder contains multiple audio files, one of the files will be read.

MS-90LP+ folder and file structure

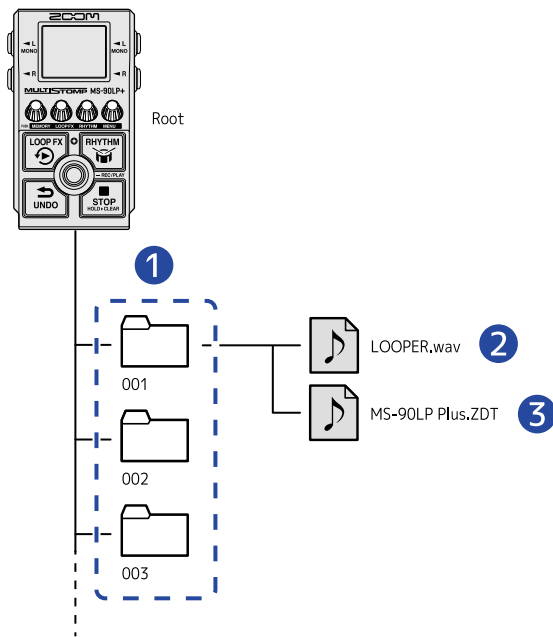

1 Memory folders

Recorded phrases, looper settings and rhythm settings, for example, are saved in these.

2 Audio file for recorded phrase

Recorded phrases are saved as stereo files.

3 Memory settings file

Disconnecting from computers, smartphones and tablets

1. Disconnect on the computer.

- Windows:
Select the MS-90LP+ with "Safely Remove Hardware and Eject Media".
- macOS:
Drag the MS-90LP+ icon to the Trash and drop it.
- Smartphone/tablet:
Refer to the operation manual for that device.

2. Press the (MEMORY) knob.

This reopens the [MENU Screen](#).

Using MIDI devices

A computer or a MIDI device that is connected to the MS-90LP+ can be used to switch memories and synchronize the tempo.

1. Connect a computer, smartphone, tablet or MIDI device to the MS-90LP+.

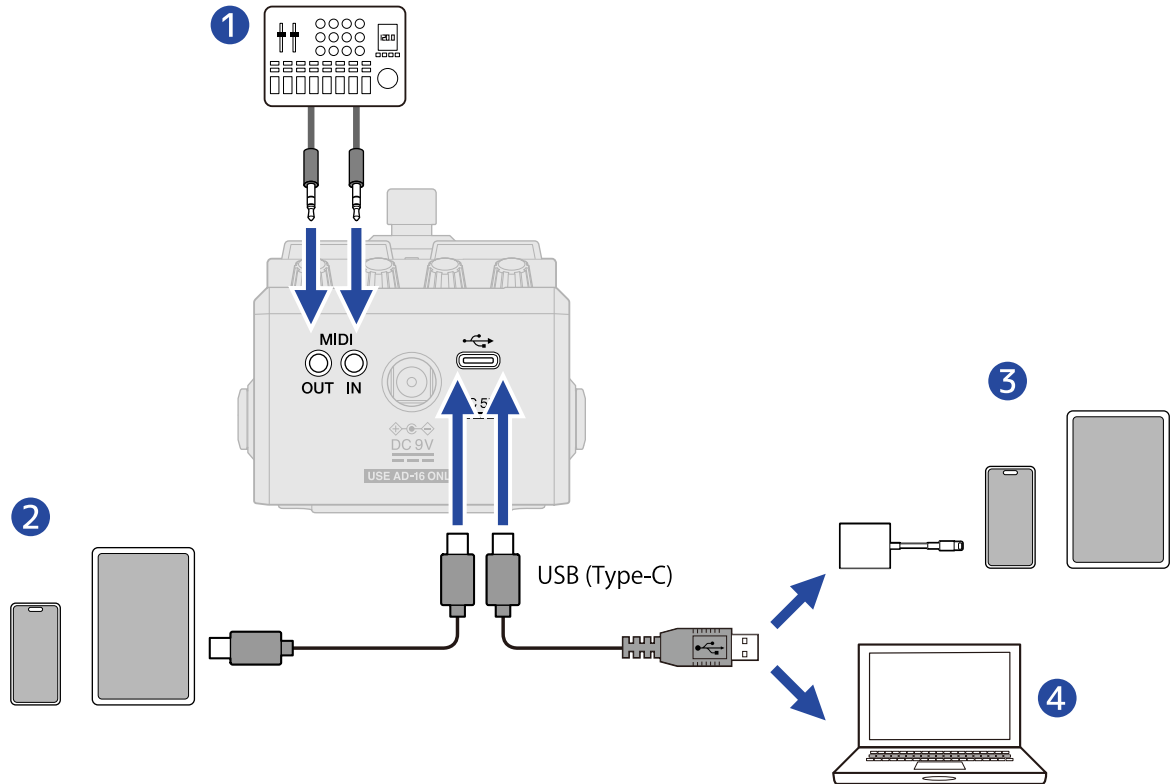

1 MIDI device

Use 3.5 mm TRS cables to connect a MIDI controller, a drum machine or another MIDI device. To connect MIDI devices with 5-pin DIN connectors, use 5-pin DIN-TRS MIDI (Type-A) conversion cables.

2 Smartphone/tablet (USB Type-C)

3 iPhone/iPad (Lightning)

4 Computer (Windows/Mac)

NOTE

- Use a USB cable that supports data transfer.
- Use a Lightning to USB 3 Camera Adapter to connect to an iPhone/iPad with a lightning connector.

2. Make MIDI settings as described in [“MIDI settings”](#).

- [Setting the channel used to receive MIDI \(MIDI RX CH\)](#)
 - [Setting the channel used to send MIDI \(MIDI TX CH\)](#)
 - [Outputting MIDI clock \(MIDI CLOCK OUT\)](#)
 - [Outputting program change messages \(PROGRAM CHANGE OUT\)](#)
 - [Setting MIDI output \(MIDI THRU\)](#)
-

HINT

See the [“MIDI implementation chart”](#) for details about MIDI data that can be used with the MS-90LP+.

Other settings (MENU Screen)

Looper settings

Setting the fade in/out time (FADE TIME)

The fade in/out time can be set when "FADE" is selected for the start or stop mode. (→ [Setting the phrase playback start mode \(START\)](#), [Setting the stop mode \(STOP\)](#))

1. Select "FADE TIME" on the [MENU Screen](#).

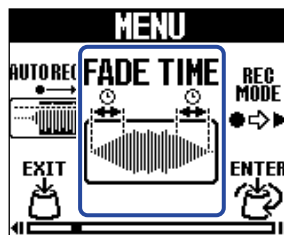

2. Turn the  (MENU) knob to set the fade in/out time.

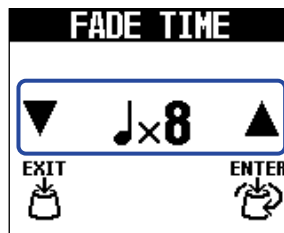

The length in notes at the set tempo is used as the fade in/out time.

3. Press the  (MENU) knob.

This confirms the setting and reopens the [Home Screen](#).

Turning automatic recording on/off (AUTO REC)

By using the automatic recording function, phrase recording can be started simultaneously with a performance.

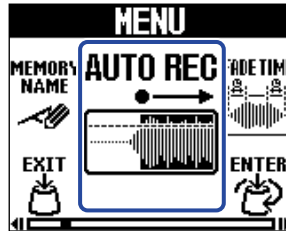

Set the sound level that starts recording.

1. Select "AUTO REC" on the [MENU Screen](#).

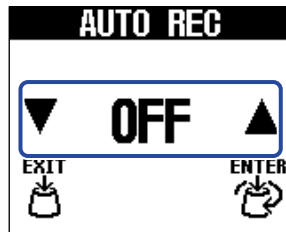

2. Turn the  (MENU) knob to select a setting.

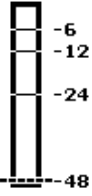

Setting	Explanation
(-6 dB - -48 dB) 	Pressing the  (footswitch) will start recording standby (and the screen will become yellow). When sound that exceeds the set value is input, recording will start (and the screen will become red).
OFF	Press the  (footswitch) to start recording at the same time.

3. Press the  (MENU) knob.

This confirms the setting and reopens the [Home Screen](#).

Selecting the operation that occurs after the first phrase recording completes (REC MODE)

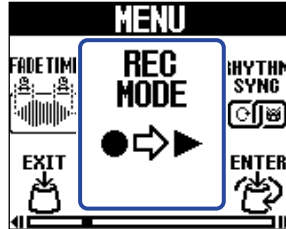

The operation that occurs when the  (footswitch) is pressed while recording the first phrase or recording reaches the set time can be set.

1. Select "REC MODE" on the [MENU Screen](#).

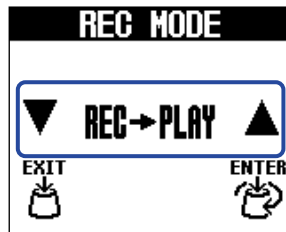

2. Turn the  (MENU) knob to select a function.



Setting	Explanation
REC->PLAY	Loop playback will start after recording of the first phrase completes.
REC->OVERDUB	Overdubbing will start after recording of the first phrase completes. Then, pressing the  (footswitch) will start loop playback.
REC->STOP	Recording will stop after recording of the first phrase completes. Then, pressing the  (footswitch) will start loop playback.

3. Press the  (MENU) knob.

This confirms the setting and reopens the [Home Screen](#).

Rhythm settings

Setting the precount (PRECOUNT)

A count sound can be played before phrase recording starts.

1. Select "PRECOUNT" on the [MENU Screen](#).

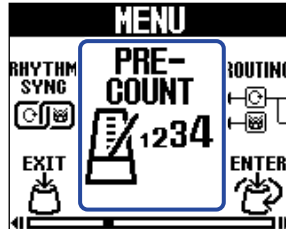

2. Turn the  (MENU) knob to switch it ON/OFF.

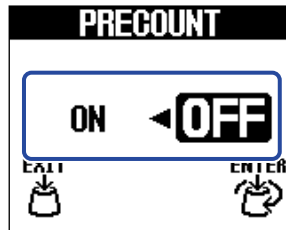

Setting	Explanation
OFF	A precount is not played.
ON	A precount is played.

3. Press the  (MENU) knob.

This confirms the setting and reopens the [Home Screen](#).

Rhythms can be synchronized with the looper (RHYTHM SYNC)

Starting/stopping phrase recording or loop playback can also start/stop the rhythm at the same time.

1. Select "RHYTHM SYNC" on the [MENU Screen](#).

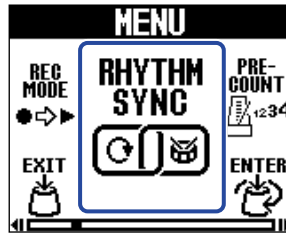

2. Turn the  (MENU) knob to switch it ON/OFF.

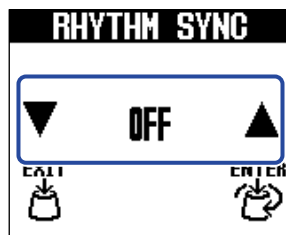

Setting	Explanation
OFF	The looper and rhythm operate separately.
START	When phrase recording or loop playback starts, the rhythm will start playback at the same time.
STOP	When phrase recording or loop playback stops, the rhythm will stop playback at the same time.
START&STOP	When phrase recording or loop playback starts, the rhythm will start playback at the same time. When phrase recording or loop playback stops, the rhythm will stop playback at the same time.

3. Press the  (MENU) knob.

This confirms the setting and reopens the [Home Screen](#).

MIDI settings

Setting the channel used to receive MIDI (MIDI RX CH)

The MIDI channel that receives data to control the MS-90LP+ can be set.

1. Select "MIDI RX CH" on the [MENU Screen](#).

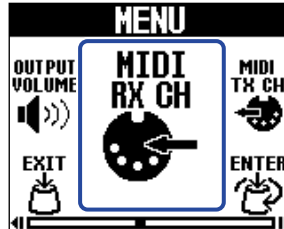

2. Turn the  (MENU) knob to set the channel used to receive MIDI.

The setting value is shown on the display.

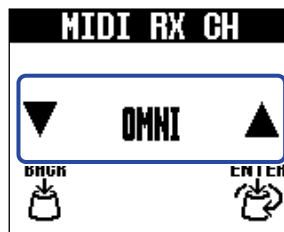

Set it to "OMNI" to receive on all MIDI channels.

3. Press the  (MENU) knob.

This confirms the setting.

4. Press the  (MEMORY) knob.

This reopens the [Home Screen](#).

Setting the channel used to send MIDI (MIDI TX CH)

The MIDI channel that the MS-90LP+ uses to transmit can be set.

1. Select "MIDI TX CH" on the [MENU Screen](#).

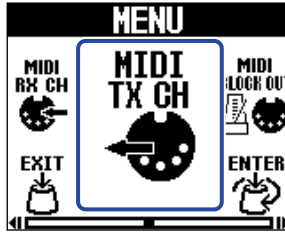

2. Turn the  (MENU) knob to set the channel used to send MIDI.

The setting value is shown on the display.

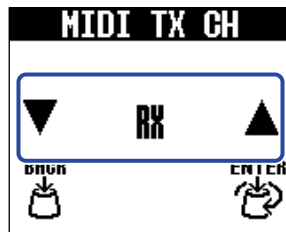

If "RX" is selected, the channel set to receive will also be used to send. (→ [Setting the channel used to receive MIDI \(MIDI RX CH\)](#))

3. Press the  (MENU) knob.

This confirms the setting.

4. Press the  (MEMORY) knob.

This reopens the [Home Screen](#).

Outputting MIDI clock (MIDI CLOCK OUT)

The MS-90LP+ can output MIDI clock to other MIDI devices.

1. Select "MIDI CLOCK OUT" on the [MENU Screen](#).

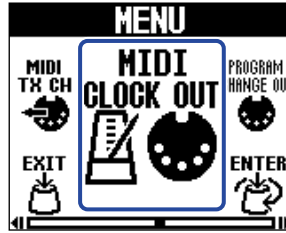

2. Turn the  (MENU) knob to switch it ON/OFF.

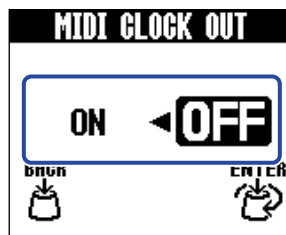

Setting	Explanation
ON	MIDI clock is output.
OFF	MIDI clock is not output.

3. Press the  (MENU) knob.

This confirms the setting.

4. Press the  (MEMORY) knob.

This reopens the [Home Screen](#).

Outputting program change messages (PROGRAM CHANGE OUT)

Program change messages can be sent to external MIDI devices when memories are changed.

1. Select "PROGRAM CHANGE OUT" on the [MENU Screen](#).

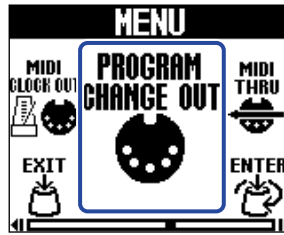

2. Turn the  (MENU) knob to switch it ON/OFF.

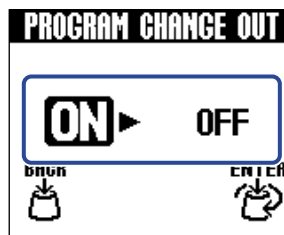

Setting	Explanation
ON	Program changes will be output.
OFF	Program changes will not be output.

3. Press the  (MENU) knob.

This confirms the setting.

4. Press the  (MEMORY) knob.

This reopens the [Home Screen](#).

Setting MIDI output (MIDI THRU)

Set which connectors output MIDI data after the data is input through the MIDI IN and USB connectors.

1. Select "MIDI THRU" on the [MENU Screen](#).

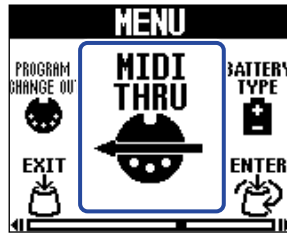

2. Turn the  (MENU) knob to select a MIDI output setting.

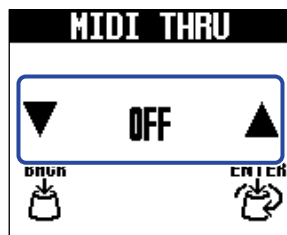

Setting	Explanation
OFF	MIDI data is not output.
MIDI OUT	MIDI data is output from the MIDI OUT jack.
USB OUT	MIDI data is output from the USB port.
USB/MIDI	MIDI data is output from the MIDI OUT jack and the USB port.

3. Press the  (MENU) knob.

This confirms the setting.

4. Press the  (MEMORY) knob.

This reopens the [Home Screen](#).

Hardware settings

Setting the output routing (ROUTING)

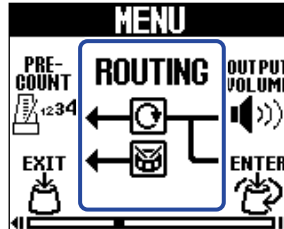

Output routing can be selected according to use.

1. Select "ROUTING" on the [MENU Screen](#).

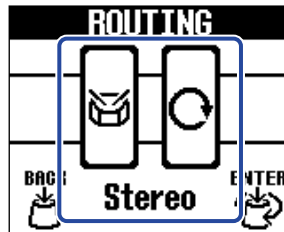

2. Turn the  (MENU) knob to select the output routing.

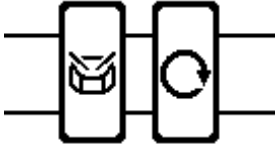

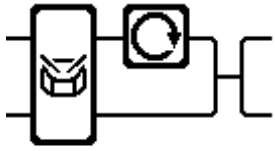
Setting	Explanation
 Stereo	The instrument, looper and rhythm sounds will be output in stereo.
 Rch-Rhythm	The rhythm sound will be output independently from the R jack. The instrument and looper sounds will be output from the L (MONO) jack in mono. This is useful for playing the rhythm through a monitor speaker or another playback device.
 Rch-Dry	The instrument sound will be output from the R jack. The looper sound will be output independently from the L (MONO) jack. (The rhythm will be output in stereo.) This is useful when you want to separately output the sound of the instrument and the looper to a mixer, for example.

3. Press the  (MENU) knob.

This confirms the setting.

4. Press the  (MEMORY) knob.

This reopens the [Home Screen](#).

Adjusting the overall output level (OUTPUT VOLUME)

The volume of the MS-90LP+ output sound can be adjusted. Reduce the volume if the output sound becomes distorted.

1. Select "OUTPUT VOLUME" on the [MENU Screen](#).



2. Turn the  (MENU) knob to adjust the volume.

The setting value is shown on the display.

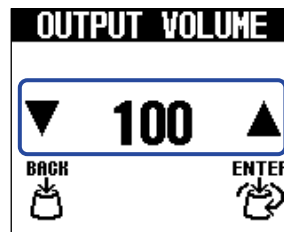

3. Press the  (MENU) knob.
This confirms the setting.

4. Press the  (MEMORY) knob.
This reopens the [Home Screen](#).

Setting the automatic saving function (AUTO SAVE)

When the AUTO SAVE function is in use, memories will be saved automatically when their contents are changed.

1. Select "AUTO SAVE" on the [MENU Screen](#).

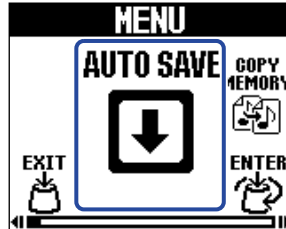

2. Turn the  (MENU) knob to select the AUTO SAVE setting.

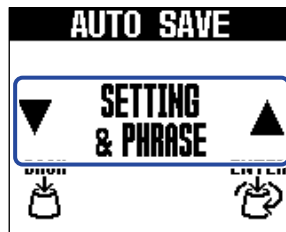

Setting	Explanation
OFF	This turns off the AUTO SAVE function.
SETTING ONLY	Only memory settings will be saved automatically.
SETTING & PHRASE	Memory settings and phrases will be saved automatically.

3. Press the  (MENU) knob.
This confirms the setting.

4. Press the  (MEMORY) knob.
This reopens the [Home Screen](#).

HINT

If the AUTO SAVE function is set to "OFF" or "SETTING ONLY", phrases will not be saved automatically. Save memories as necessary. (→ [Saving memories \(SAVE MEMORY\)](#))

Setting the battery type (BATTERY TYPE)

Set the type of battery used correctly so that the amount of remaining battery charge can be monitored accurately.

1. Select "BATTERY TYPE" on the [MENU Screen](#).

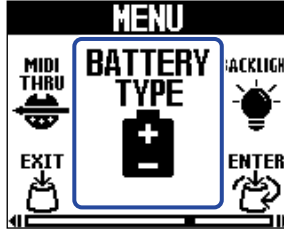

2. Turn the  (MENU) knob to select the type of battery used.

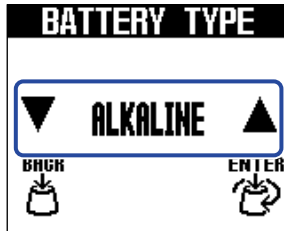

Setting	Explanation
ALKALINE	Alkaline batteries
Ni-MH	Nickel-metal hydride batteries
LITHIUM	Lithium batteries

3. Press the  (MENU) knob.

This confirms the setting.

4. Press the  (MEMORY) knob.

This reopens the [Home Screen](#).

Adjusting the backlight brightness (BACKLIGHT)

The brightness of the backlight can be adjusted. Select "NORMAL" to extend battery life.

1. Select "BACKLIGHT" on the [MENU Screen](#).

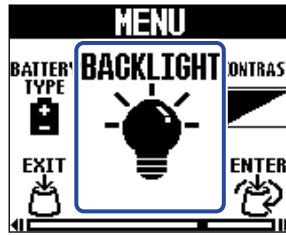

2. Turn the  (MENU) knob to adjust the backlight brightness.

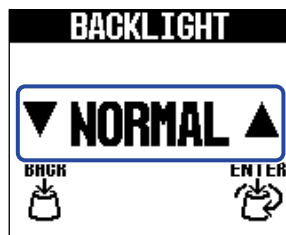

Setting	Explanation
NORMAL	This is regular brightness.
BRIGHT	This makes the backlight brighter.

3. Press the  (MENU) knob.

This confirms the setting.

4. Press the  (MEMORY) knob.

This reopens the [Home Screen](#).

Adjusting the display contrast (CONTRAST)

Adjust the display contrast.

1. Select "CONTRAST" on the [MENU Screen](#).

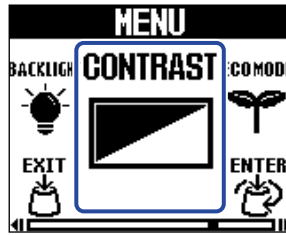

2. Turn the  (MENU) knob to adjust the display contrast.

The setting value is shown on the display.

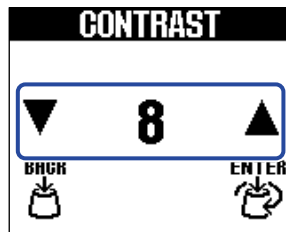

3. Press the  (MENU) knob.

This confirms the setting.

4. Press the  (MEMORY) knob.

This reopens the [Home Screen](#).

Setting the ECO MODE

This function can be used to turn the power off automatically if unused for 10 hours.

1. Select "ECO MODE" on the [MENU Screen](#).

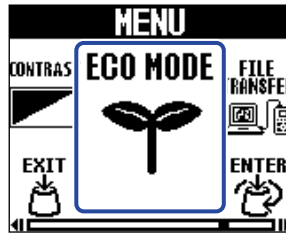

2. Turn the  (MENU) knob to switch it ON/OFF.

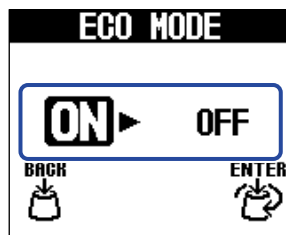

Setting	Explanation
ON	The power will automatically turn off if unused for 10 hours.
OFF	This disables ECO mode.

3. Press the  (MENU) knob.

This confirms the setting.

4. Press the  (MEMORY) knob.

This reopens the [Home Screen](#).

Managing the firmware

Checking the firmware version (VERSION)

The version of the firmware used by the MS-90LP+ can be checked.

1. Select "VERSION" on the [MENU Screen](#).

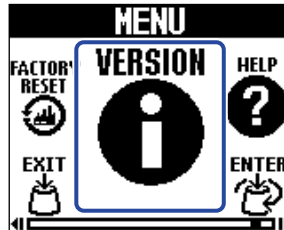

2. Check the version on the VERSION Screen.
This shows the firmware and preset versions.

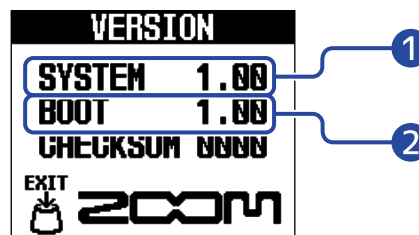

- 1 MS-90LP+ firmware version
- 2 Boot version

3. Press the  (MEMORY) knob.

This reopens the [Home Screen](#).

Updating the firmware

The MS-90LP+ firmware can be updated to the latest version.

The latest firmware can be downloaded from the ZOOM website (zoomcorp.com/help/ms-90lpplus).

Restoring default settings (FACTORY RESET)

Settings can be restored to the factory defaults.

1. Select "FACTORY RESET" on the [MENU Screen](#).

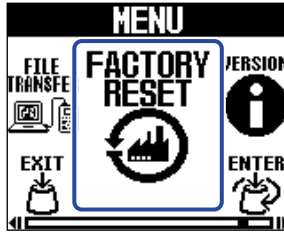

2. Turn the  (MENU) knob to select "YES".



3. Press the  (MENU) knob.

Resetting will be executed, restoring default settings.



NOTE

Resetting will overwrite all settings, including memories, with their factory defaults. Be certain before using this function.

HINT

To cancel resetting, select "NO" in step 2.

Checking the latest MS-90LP+ information (HELP)

A 2D code for help related to the MS-90LP+ can be shown on its display.

1. Select "HELP" on the [MENU Screen](#).

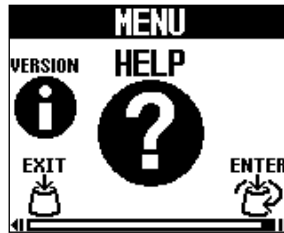

2. Use a smartphone or tablet, for example, to read the 2D code shown on the HELP Screen.



zoomcorp.com/help/ms-90lpplus

3. Press the  (MEMORY) knob.
This reopens the [Home Screen](#).

Appendix

Troubleshooting

The unit will not power on

- If using batteries, connect a cable to the L/MONO output jack. (→ [Turning the power on/off](#))
- Check the connections. (→ [Making connections](#))
- If the indicator blinks and it will not start, update the firmware. (→ [Updating the firmware](#))

There is no sound or output is very quiet

- Check the connections. (→ [Making connections](#))
- Adjust the looper and rhythm levels. (→ [Adjusting the looper volume \(LOOP VOL\)](#), [Setting the rhythm volume \(VOLUME\)](#))
- Adjust the output volume. (→ [Adjusting the overall output level \(OUTPUT VOLUME\)](#))

There is a lot of noise

- Confirm that an instrument cable is not the cause.
- Use a genuine ZOOM AC adapter. (→ [Making connections](#))

Batteries lose their charge quickly

Making the following settings could increase the battery operation time.

- Set the type of battery used correctly. (→ [Setting the battery type \(BATTERY TYPE\)](#))
- Set the display backlight to "NORMAL". (→ [Adjusting the backlight brightness \(BACKLIGHT\)](#))
- Due to their characteristics, using nickel metal hydride batteries (especially high-capacity ones) or lithium batteries should enable longer use than alkaline batteries when power consumption is high.

Specifications

Number of memories		100
Sampling frequency		44.1 kHz
Signal processing		32-bit float
Number of recording and playback tracks		1
Data format		WAV (44.1 kHz, stereo, 32-bit floating-point)
Maximum recording times		90 minutes (1 loop) / 13 hours or more (total for all memories)
Frequency response		20 Hz – 20 kHz (+0.5 dB/–0.5 dB) (when 10kΩ load)
Display		160×128 dot-matrix LCD with color backlight
Inputs	L/R	Standard mono phone jacks Rated input level: –20 dBu Input impedance (line): 470 kΩ
Outputs	L/R	Standard mono phone jacks Maximum output level: +7.2 dBu (when output impedance 10 kΩ or higher)
MIDI IN/OUT jacks		Stereo mini jack
Input S/N		122 dB
Noise floor (residual noise)		–100 dBu
Power		AC adapter: 9V DC 500mA center negative (ZOOM AD-16) 2 AA batteries (alkaline, lithium or rechargeable NiMH batteries)
Estimated operation times using batteries	<ul style="list-style-type: none"> • These values are approximate. • Battery operation times were determined using in-house testing methods. They will vary greatly according to use conditions. 	Alkaline batteries: about 4.0 hours (about 3.5 hours using stereo input) NiMH batteries (1900 mAh): about 5 hours (about 4.5 hours using stereo input) Lithium batteries: about 9 hours (about 8 hours using stereo input)
USB		Port: USB 2.0 Type-C / Supported cable type: Type-C USB MIDI: USB1.1 Full Speed File transfer: USB 2.0 High Speed <ul style="list-style-type: none"> • Use a USB cable that supports data transfer. USB bus power is supported.
Dimensions		133 mm (D) × 79 mm (W) × 61 mm (H)

Weight

367 g (excluding batteries)

414 g (including batteries)

Note: 0 dBu = 0.775 V

MIDI implementation chart

[MultiStomp]

Model: MS-90LP+
MIDI implementation chart

Date: Oct. 1, 2024
Version: 1.00

Function		Transmitted	Recognized	Remarks
Basic Channel	Default	1-16	1-16	Memorized
	Changed	1-16	1-16	
Mode	Default	x	x	
	Messages Altered	x *****	x	
Note Number	True voice	x	x	

Velocity	Note ON	x	x	
	Note OFF	x	x	
Aftertouch	Key	x	x	
	Channel	x	x	
Pitch Bend		x	x	
Control Change	0-127	x	x	
Program Change		o (0-99)	o (0-99)	
	True Number	*****	0-99	
System Exclusive		x	x	
System Common	Song Position	x	x	
	Song Select	x	x	
	Tune Request	x	x	
System Realtime	Clock	o	o	
	Commands	o	x	
Aux Messages	Local ON/OFF	x	x	
	All Notes OFF	x	x	
	Active Sense	x	x	
	System Reset	x	x	

Notes

Mode 1: OMNI ON, POLY

Mode 2: OMNI ON, MONO

o: Yes

Mode 3: OMNI OFF, POLY

Mode 4: OMNI OFF, MONO

x: No



ZOOM CORPORATION

4-4-3 Kanda-surugadai, Chiyoda-ku, Tokyo 101-0062 Japan

zoomcorp.com