

MS-70CDR+

MULTISTOMP

Patch Memory List

Preset Ver. 1.00

This preset patch memory will provide optimal tone when connected to a guitar amp.
Enjoy using the MS-70CDR+ connected to a guitar amp.

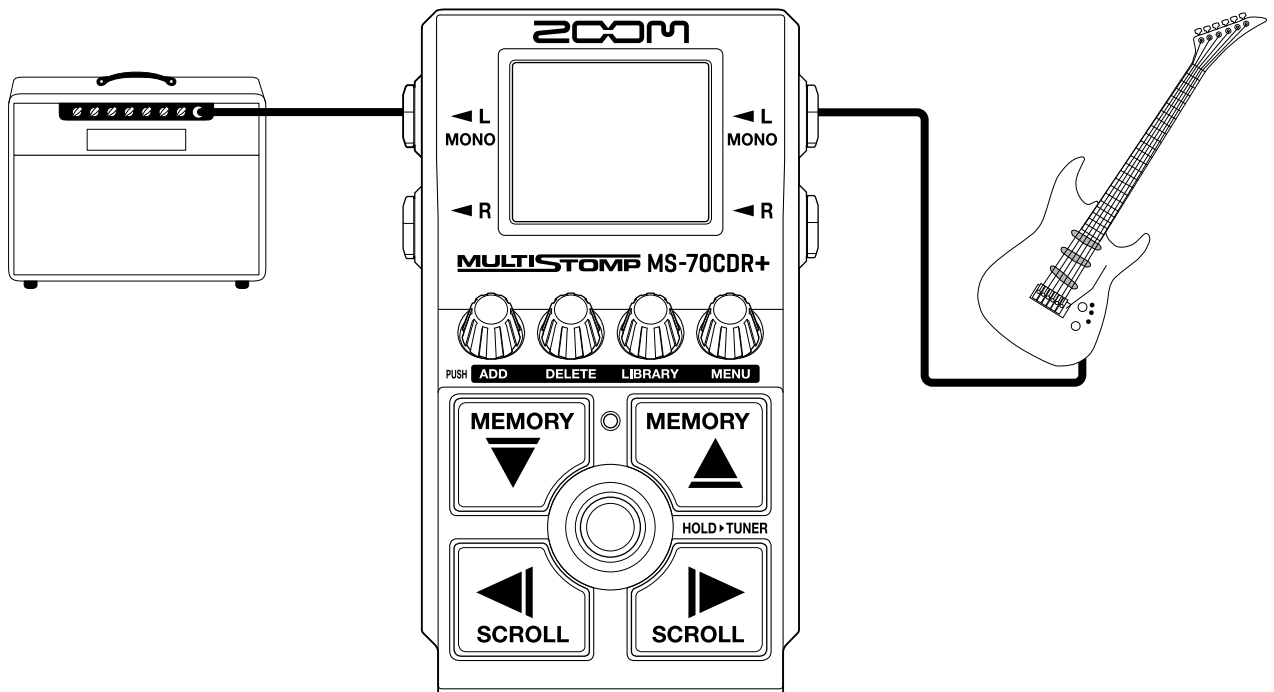

© 2024 ZOOM CORPORATION

Copying or reprinting this manual in part or in whole without permission is prohibited.

Product names, registered trademarks and company names in this document are the property of their respective companies. All trademarks and registered trademarks in this document are for identification purposes only and are not intended to infringe on the copyrights of their respective owners.

This document cannot be displayed properly on black-and-white displays.

DEMO

001 : C-D-R+

This combines chorus, delay and reverb for a sound that is deep and wide.

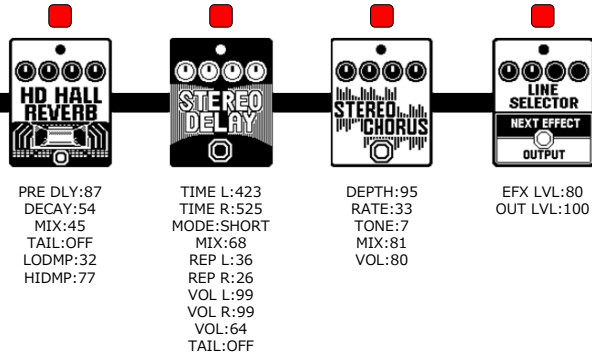

002 : '63 Spring Reverb

This vintage surf sound combines tremolo with a '63 Fender Reverb model.

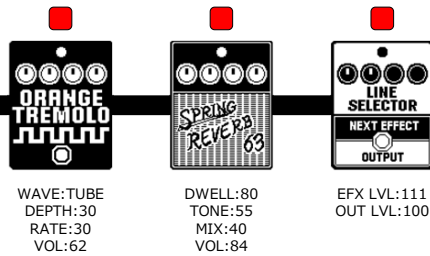

003 : Silky Tape Echo

Silky Chorus and AC Tape Echo are combined for this smooth tape echo sound.

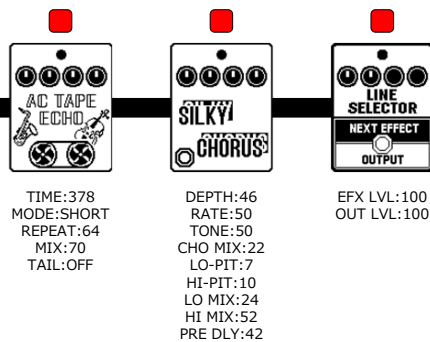

004 : Phase Room

This phase sound is a match for funky playing whether guitar or bass.

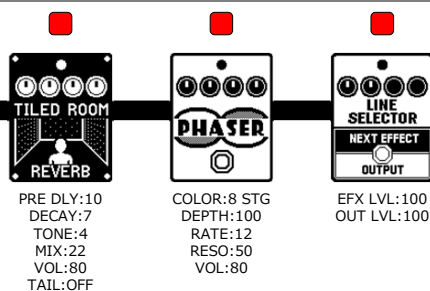

DEMO

005 : Shimmer Reverb+

The pitch of the reverberation sound rises continuously in this magical reverb.



PRE DLY:40
DECAY:79
MIX:71
TAIL:OFF
LO-DMP:80
HI-DMP:55

006 : Long Echo

This long delay sound uses the Soft Echo effect.



PRE DLY:15
DECAY:50
COLOR:45
MIX:20
LODMP:78
HIDMP:64
VOL:80
TAIL:OFF



MOD:ON
TIME:561
REPEAT:35
MIX:68
WIDTH:27
SPEED:31
TAIL:OFF



EFX LVL:100
OUT LVL:100

007 : 69s Vibe

This vintage vibe sound features a unique undulation.



PRE DLY:29
DECAY:34
TONE:73
MIX:65
DRY:ON
TAIL:OFF



SPEED:21
DEPTH:38
MODE:CHORS
VOL:80
WAVE:41
BIAS:47



EFX LVL:100
OUT LVL:100

008 : Mangle Ice

Combining Strymon TimeLine ICE and Eventide Space MangledVerb models, this creates a sepia tone with little sense of color.



160Hz:-3.0
400Hz:-5.0
800Hz:0.0
3.2kHz:0.0
6.4kHz:1.0
12kHz:0.0
VOL:100



PRE DLY:101
DECAY:41
SIZE:71
MIX:21
CLIP:25
DEPTH:95
LO:-13
HI:6
VOL:57



INTVL:5
TIME:500
MODE:SHORT
REPEAT:68
MIX:44
BLEND:13
SMEAR:6
DAMP:8
HPF:60
SLICE:LONG

DEMO

009 : LO-FI Noise

Using a Strymon TimeLine model, this provides a dark spatial sound with an aura of lo-fi noise.



PRE DLY:10
DECAY:20
TONE:5
MIX:40
VOL:80
TAIL:OFF



TIME:500
MODE:SHORT
REPEAT:21
MIX:40
DEPTH:100
RATE:10
RESO:8
VOL:80
TAIL:OFF



TIME:250
MODE:SHORT
REPEAT:22
MIX:32
SAMPLE:1/10
BIT:5
BLEND:80
DAMP:9
FILTER:3
VINYL:D:4

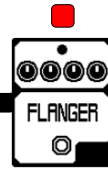

PRE DLY:15
DEPTH:47
RATE:7
RESO:8
MIX:20
VOL:80

010 : Small & Smooth

This all-around clean sound utilizes an Electro-Harmonix Small Clone model.



PRE DLY:21
DECAY:21
MIX:60
TONE:8
VOL:80
TAIL:OFF



TIME:360
MODE:SHORT
REPEAT:35
MIX:35
TONE:45
TAIL:OFF



DEPTH:2
RATE:22
TONE:100
MIX:100



EFX LVL:100
OUT LVL:100

011 : Modulation Delay 1&2

This sound combines two types of modulation delay.

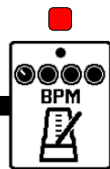

BPM:120



TIME:4TH
MODE:BPM
SYNC
REPEAT:50
MIX:38
DEPTH:61
RATE:11
VOL:80
TAIL:OFF

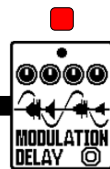

TIME:4TH
MODE:BPM
SYNC
REPEAT:41
MIX:29
RATE:21
VOL:80
TAIL:OFF



EFX LVL:100
OUT LVL:100

012 : Pipe Organ

This pipe organ sound supports chords.



PRE DLY:89
DECAY:52
TONE:70
MIX:44
HIDMP:86
DRY:ON
TAIL:OFF



CENT:14
PRE DLY:0
TONE:8
MIX:52
VOL:80

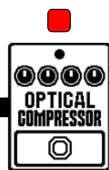

DRIVE:8
LO:45
HI:50
VOL:17



LO:38
HI:70
WET:62
DRY:80



SHIFT:24
TONE:73
WET:37
DRY:80



EFX LVL:85
OUT LVL:100

DEMO

013 : Pop Chorus

This simple chorus sound is perfect for pop music.

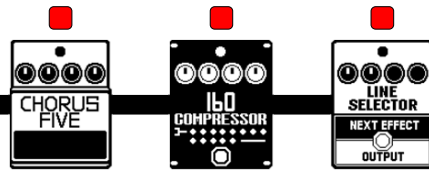

CHORUS FIVE

160 COMPRESSOR

LINE SELECTOR

DEPTH:70
RATE:31
OUTPUT:MONO
MIX:65
LO:42
HI:52

THRSHLD:-34
RATIO:2.1
KNEE:HARD
VOL:53

EFX LVL:100
OUT LVL:100

014 : Deep Blue

This sound evokes the deep sea.

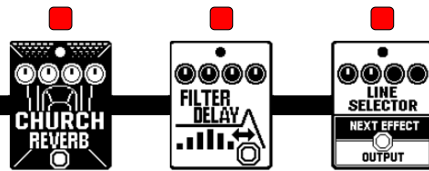

CHURCH REVERB

FILTER DELAY

LINE SELECTOR

PRE DLY:87
DECAY:63
TONE:61
MIX:34
HIDMP:86
DRY:ON
TAIL:OFF

TIME:500
MODE:SHORT
REPEAT:30
MIX:46
DEPTH:50
RATE:10
RESO:9
VOL:80
TAIL:OFF

EFX LVL:100
OUT LVL:100

015 : Dual Reverb

This combines two reverbs for this reverb sound with a layered feeling.



PRE DLY A:18
PRE DLY B:301
A-B MIX:A6B9
MIX:30
DECAY A:20
DECAY B:35
TONE A:0
TONE B:-35
SIZE:A4B9

016 : Rotary

This sound is a rotary speaker simulation.

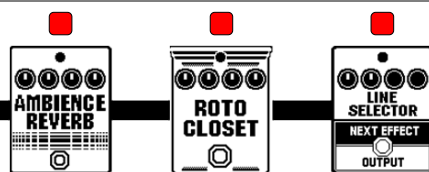

AMBIENCE REVERB

ROTO CLOSET

LINE SELECTOR

PRE DLY:29
DECAY:70
TONE:80
MIX:62
DRY:ON
TAIL:OFF

MODE:FAST
DRIVE:30
BAL:49
VOL:69

EFX LVL:80
OUT LVL:100

DEMO

017 : Stairway

This uses two Pitch Delay effects to produce a sound with a four-note phrase.

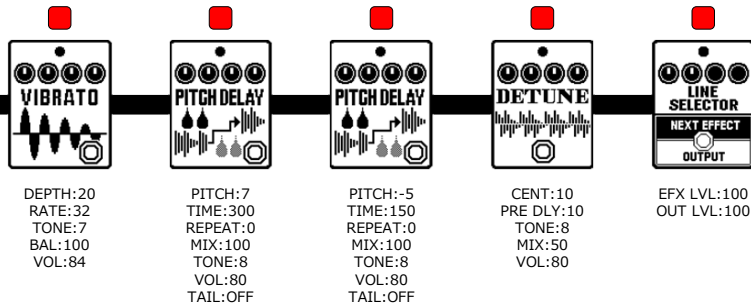

018 : Tape Echo 3

Combining a model of the Maestro Echoplex EP-3 with a dense reverb produces this warm and deep echo sound.

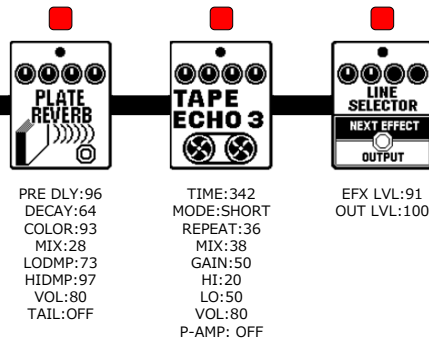

019 : Filter Pad

This can generate a synthesizer pad sound from guitar. This is a pleasant enveloping sound.

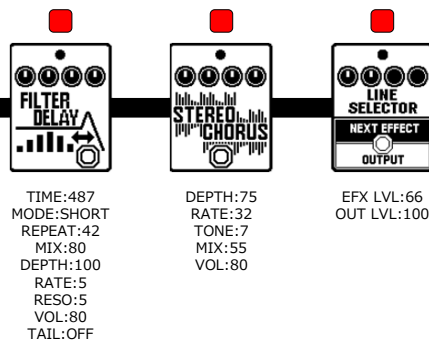

020 : BPM Sync Delay



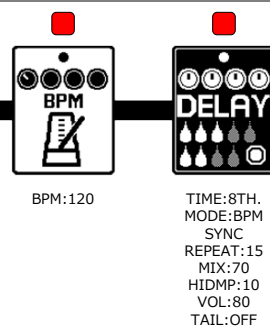

This dotted eighth note delay is synchronized to the BPM set using tap tempo.



DEMO













021 : Kick Flanger

This flanger turns on only while the footswitch is being pressed.

 	 
<p>PRE DLY:13 DECAY:47 COLOR:58 MIX:49 LODMP:96 HIDMP:93 VOL:80 TAIL:OFF</p>	<p>PRE DLY:8 DEPTH:61 RATE:39 RESO:69 MIX:100 RESET-F:21 ON/ OFF:UNLATCH</p>

022 : Ambient

This ambient sound generates a deep and wide reverb.

 	 	 	 	 	 
<p>PRE DLY:131 DECAY:62 TONE:85 MIX:60 HIDMP:86 DRY:ON TAIL:OFF</p>	<p>PRE DLY:51 DECAY:29 TONE:8 MIX:52 DEPTH:42 RATE:14 VOL:80 TAIL:OFF</p>	<p>TIME:3000 MODE:LONG PTRRN:2 MIX:36 TONE:5 VOL:80 TAIL:OFF</p>	<p>TIME:320 MODE:SHORT REPEAT:62 MIX:40 GAIN:63 HI:59 LO:21 VOL:80 P-AMP: OFF</p>	<p>TIME:1410 MODE:LONG REPEAT:20 BAL:31 HIDMP:10 VOL:80 TAIL:OFF</p>	<p>EFX LVL:53 OUT LVL:100</p>

Chorus / Modulation

023 : Chorus One

This models a BOSS Super Chorus CH-1.



DEPTH:53
RATE:19
TONE:50
MIX:70
OUTPUT:MONO

024 : Green Chorus

This models a TC Electronic CORONA CHORUS.



DEPTH:37
SPEED:57
TONE:80
MIX:70
DRY:ON

025 : Orange Tremolo

This is a tremolo sound that raises and lowers the volume cyclically.



WAVE:TRI
DEPTH:75
RATE:42
VOL:62

026 : Vibrato

This is a practical vibrato sound.



DEPTH:58
RATE:30
TONE:6
BAL:75
VOL:84

Chorus / Modulation

027 : Swell Vibrato

This vibrato sound varies the pitch after picking.



DEPTH:28
SPEED:44
RISE:60
VOL:80

028 : Analog Chorus

This 80s chorus sound uses Analog Chorus.



DEPTH:76
RATE:35
MIX:75
LO:60
HI:98
OUTPUT:MONO

029 : BF Flanger 2

This models a BOSS BF-2 Flanger.



PRE DLY:100
DEPTH:80
RATE:30
RESO:50

030 : Jet Flanger

This jet flanger sound is like an A/DA Flanger.



PRE DLY:4
DEPTH:47
RATE:7
RESO:8
MIX:65
VOL:80

Chorus / Modulation

031 : Clone Chorus

This models an Electro-Harmonix Small Clone.



DEPTH:2
RATE:26
TONE:100
MIX:100

032 : Detune

This detuned sound produces a chorus effect with little variation.



CENT:6
PRE DLY:3
TONE:10
MIX:50
VOL:80

033 : Phaser

This phaser sound adds a bubbly undulation.



COLOR:INV 8
DEPTH:94
RATE:12
RESO:50
VOL:80

034 : Duo Phaser

This effect combines two phasers.



DEPTH A:63
RATE A:6
RESO A:6
LINK:SERIAL
DEPTH B:37
RATE B:47
RESO B:0
VOL:80

Chorus / Modulation

035 : Tremolo-Pan

This is a practical amplitude modulation sound. This produces a tremolo effect when mono and an auto-pan effect when stereo.



RATE:31
WIDTH:R20
CLIP:0
DEPTH:7
VOL:88

036 : Slicer

This effect produces a rhythmical sound by continuously slicing the input.



PTRN:7
SPEED:45
THRSH:20
BAL:100
VOL:87

037 : Tri Chorus

This high-quality chorus sound with little variation models a TC Electronic CORONA CHORUS Tri-Chorus.



DEPTH:91
SPEED:30
TONE:80
MIX:79
DRY:ON

038 : Polyphonic Octaver

This octaver sound adds pitches one octave below.



LO:50
HI:100
WET:73
DRY:82

Chorus / Modulation

039 : Bass Analog Octaver

This simulates an analog octaver. It applies modulation to the octave below, adding depth to the sound.



OCT1:65
OCT2:5
MOD:25
DRY:80

040 : Polyphonic Pitch Shifter

This pitch shifter supports chords.



SHIFT:12
TONE:46
WET:55
DRY:80

041 : Geminus Doubler

This effect can make a double-tracking sound in real time. The effect is maximized in stereo.



TIGHT:50
MODE:ST-2
WET:75
DRY:75

Delay / Reverb

042 : AC Tape Echo

This is a deep echo sound adjusted for acoustic instruments.



TIME:330
MODE:SHORT
REPEAT:55
MIX:60
TAIL:OFF

043 : Smooth Delay

This practical delay sound can generate a sense of reverb with just a delay.



TIME:360
MODE:SHORT
REPEAT:45
MIX:40
TONE:45
TAIL:OFF

044 : Rockabilly

Modeling a TC Electronic Flashback Slap, this is a practical short delay sound.



TIME:100
REPEAT:20
MIX:46
SUBDV:4TH
OUTPUT:MONO
DRY:ON
TAIL:ON

045 : Digital Delay

This is a clear digital delay sound.



TIME:330
MODE:SHORT
REPEAT:33
MIX:42
HIDMP:10
VOL:80
TAIL:OFF

Delay / Reverb

046 : Soft Echo

This standard analog delay sound uses the Soft Echo effect.



MOD:ON
TIME:345
REPEAT:40
MIX:50
WIDTH:27
SPEED:31
TAIL:OFF

047 : Drive Echo

This echo effect is inspired by Maestro Echoplex EP-1 and can add drive to the sound.



TIME:4TH
MODE:BPM
SYNC
REPEAT:70
MIX:80
DRIVE:39
WOW:25
DRY:DRIVE
OUTPUT:MONO
TAIL: OFF

048 : Dual Delay

This effect can combine two independent delays.



TIMEA:4TH
TIMEB:8TH.
MODE:BPM
SYNC
BAL:50
REP A:50
REP B:50
DLYMX:25
FLTR:0
DEPTH:MN-0
SPEED:25

049 : Trigger Hold Delay

This delay uses picking as the trigger for sample and hold.



TIME:50
MODE:SHORT
DUTY:100
MIX:100
SENSE:20
VOL:80
TAIL:OFF

Delay / Reverb

050 : Drunkship

This psychedelic modulation delay sound uses the Filter Delay.



TIME:200
MODE:SHORT
REPEAT:70
MIX:73
DEPTH:60
RATE:36
RESO:6
VOL:80
TAIL:OFF

051 : FD Spring Reverb

This simulates the spring reverb of the '65 Fender Twin Reverb.



COLOR:0
LO:73
HI:80
MIX:33

052 : Chamber Reverb

This reverb sound simulates the echoes of a chamber.



PRE DLY:24
DECAY:50
TONE:73
MIX:42
TAIL:OFF

053 : Church Reverb

This spacious reverb simulates the sound of a church.



PRE DLY:135
DECAY:57
TONE:61
MIX:35
HIDMP:84
DRY:ON
TAIL:OFF

Delay / Reverb

054 : Cave Reverb

This reverb simulates the sound of echoes in a cave.



PRE DLY:62
DECAY:52
TONE:54
MIX:42
TAIL:OFF

055 : Slap Back Reverb

This reverb can generate repeated echoes.



DECAY:17
TIME:471
REPEAT:50
MIX:49
D-R BAL:70
TONE:10
VOL:80
TAIL:OFF

056 : Gate Reverb

This unique reverb is good for percussive playing.



COLOR:1
DECAY:65
TONE:50
BAL:60
TAIL:OFF

057 : Long Plate

This reverb sound has the beguiling echoes characteristic of plate reverb.



PRE DLY:96
DECAY:60
COLOR:100
MIX:47
LODMP:73
HIDMP:97
VOL:80
TAIL:OFF

Delay / Reverb

058 : Loop Roll

This effect allows you to use the footswitch to sample and hold what you play.

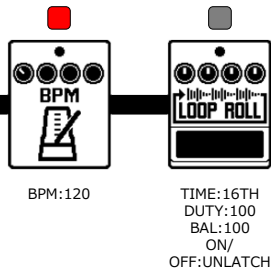

059 : Hold Delay

This hold delay effect is controlled using the footswitch.

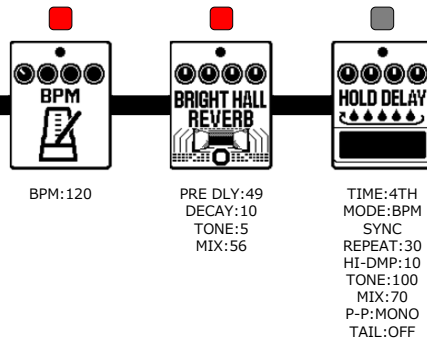

060 : Hold Reverb

This hold reverb effect is controlled using the footswitch.

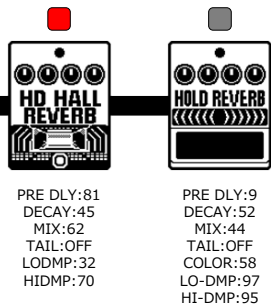

061 : Higher

This synthesizer-like sound spreads out as the pitch rises.

The effect chain for 'Higher' consists of five modules: SHIMMER REVERB+, ICE DELAY, PITCH DELAY, BEND CHORUS, and LINE SELECTOR. Each module has a red square above it and a control panel with knobs and buttons.

SHIMMER REVERB+ PRE DLY:83 DECAY:80 MIX:75 TAIL:OFF LO-DMP:80 HI-DMP:67	ICE DELAY INTVL:OCT TIME:330 MODE:SHORT REPEAT:61 MIX:48 BLEND:16 SMEAR:13 DAMP:7 HPF:160 SLICE:LONG	PITCH DELAY PITCH:7 TIME:90 REPEAT:80 MIX:80 TONE:8 VOL:80 TAIL:OFF	BEND CHORUS MODE:UP DEPTH:72 TIME:50 BAL:100 TONE:5	LINE SELECTOR EFX LVL:50 OUT LVL:100
--	---	---	---	---

062 : Guitar Strings

This creates a guitar string ensemble.

The effect chain for 'Guitar Strings' consists of five modules: PLATE REVERB, SLOW ATTACK DELAY, STEREO CHORUS, POLYPHONIC PITCH SHIFTER, and LINE SELECTOR. Each module has a red square above it and a control panel with knobs and buttons.

PLATE REVERB PRE DLY:16 DECAY:53 COLOR:58 MIX:50 LODMP:97 HIDMP:95 VOL:80 TAIL:OFF	SLOW ATTACK DELAY SWELL:34 TIME:500 MODE:SHORT REPEAT:62 MIX:53 DEPTH:45 OUTPUT:MONO TAIL:ON	STEREO CHORUS DEPTH:100 RATE:28 TONE:7 MIX:50 VOL:80	POLYPHONIC PITCH SHIFTER SHIFT:12 TONE:100 WET:40 DRY:70	LINE SELECTOR EFX LVL:110 OUT LVL:100
---	---	--	---	--

063 : Pad Guitar

This is a keyboard-style pad sound. This is good even when finger-playing with a light touch.

The effect chain for 'Pad Guitar' consists of five modules: CAVE REVERB, MODULATION DELAY 2, REVERSE DELAY, POLYPHONIC PITCH SHIFTER, and LINE SELECTOR. Each module has a red square above it and a control panel with knobs and buttons.

CAVE REVERB PRE DLY:124 DECAY:52 TONE:50 MIX:40 TAIL:OFF	MODULATION DELAY 2 TIME:500 MODE:SHORT REPEAT:10 MIX:36 DEPTH:100 RATE:17 VOL:80 TAIL:OFF	REVERSE DELAY TIME:500 MODE:SHORT REPEAT:9 BAL:85 HIDMP:8 VOL:80 TAIL:OFF	POLYPHONIC PITCH SHIFTER SHIFT:12 TONE:100 WET:50 DRY:80	LINE SELECTOR EFX LVL:100 OUT LVL:100
--	--	---	---	--

064 : Synchronized

This sound generates a rhythmical effect synchronized to the BPM.

The effect chain for 'Synchronized' consists of six modules: BPM, AUTO PAN, DUAL DELAY, SLICER, PHASER, and LINE SELECTOR. Each module has a red square above it and a control panel with knobs and buttons.

BPM BPM:120	AUTO PAN TIME:16TH MODE:BPM SYNC REPEAT:84 MIX:59 LINK:DLY-PAN CYCLE:50 WIDTH:0 DEPTH:7 CLIP:0 VOL:80	DUAL DELAY TIMEA:4TH TIMEB:8TH MODE:BPM SYNC BAL:50 REP A:40 REP B:40 DLYMX:50 FLTR:38 DEPTH:ST-31 SPEED:15	SLICER PTRN:5 SPEED:16TH THRS:20 BAL:100 VOL:81	PHASER COLOR:INV 4 DEPTH:100 RATE:4THX16 RESO:50 VOL:80	LINE SELECTOR EFX LVL:100 OUT LVL:100
-----------------------	---	---	---	---	--

065 : Reverse

This instantly accentuates solos whether guitar or bass.

BASS FLANGER

PRE DLY:2
DEPTH:80
RATE:30
RESO:3
LOCUT: 60Hz
MIX:100
VOL:76

REVERSE DELAY

TIME:1000
MODE:LONG
REPEAT:12
BAL:29
HIDMP:8
VOL:80
TAIL:OFF

LINE SELECTOR

EFX LVL:75
OUT LVL:100

066 : 12 Strings

This combines Polyphonic Pitch Shifter and Detune for a sound like a 12-string guitar.

SPRING REVERB 63

DWELL:8
TONE:53
MIX:21
VOL:80

DETUNE

CENT:7
PRE DLY:0
TONE:8
MIX:42
VOL:80

POLYPHONIC PITCH SHIFTER

SHIFT:12
TONE:74
WET:47
DRY:80

LINE SELECTOR

EFX LVL:90
OUT LVL:100

067 : Delay & Delay

This quirky delay sound with lengthy repetitions combines long and short delays.

TILED ROOM REVERB

PRE DLY:10
DECAY:20
TONE:4
MIX:46
VOL:80
TAIL:OFF

STEREO GUITAR GRAPHIC EQ

160Hz:-1.0
400Hz:-1.0
800Hz:-2.0
3.2kHz:3.0
6.4kHz:0.0
12kHz:0.0
VOL:80

MULTI TAP DELAY

TIME:1720
MODE:LONG
PTTRN:6
MIX:80
TONE:8
VOL:80
TAIL:OFF

DUAL DELAY

TIMEA:1000
TIMEB:70
MODE:TIME
BAL:95
REP A:75
REP B:86
DLYMX:34
FLTR:10
DEPTH:MN-23
SPEED:21

LINE SELECTOR

EFX LVL:80
OUT LVL:100

068 : Mono Synth

This is a funky synthesizer sound for playing single notes.

LOW-PASS FILTER

FREQ:68
SENSE:FST78
RESO:2P-5
BAL:90

POLYPHONIC OCTAVER

LO:50
HI:70
WET:40
DRY:80

POLYPHONIC PITCH SHIFTER

SHIFT:12
TONE:81
WET:42
DRY:80

MONO SYNTH

WAVE:SAWUP
SPEED:0
TONE:8
SYNTH:86
DRY:29
VOL:28

LINE SELECTOR

EFX LVL:100
OUT LVL:100

069 : Voice Reverse

This ambient sound with a reverse effect evokes a human voice.

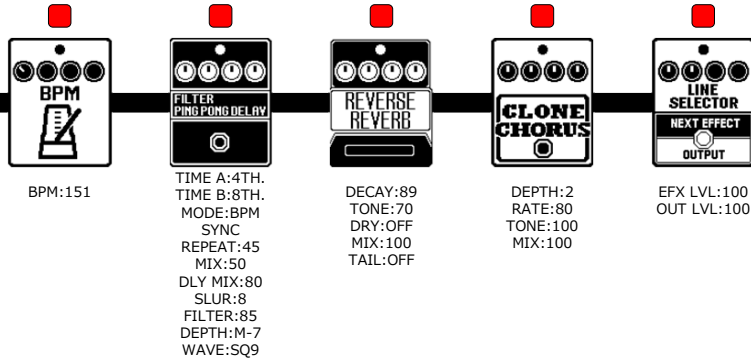

070 : Sequence Filter

This phantasmal sound combines Sequence Filter with Holy Reverb.

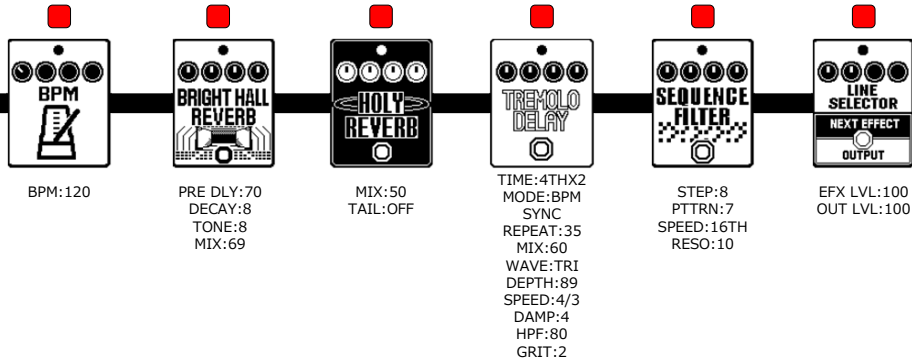

071 : Hollywood

Using modeling of the Line 6 M9 Particle Verb, this grand sound is like a film special effect.

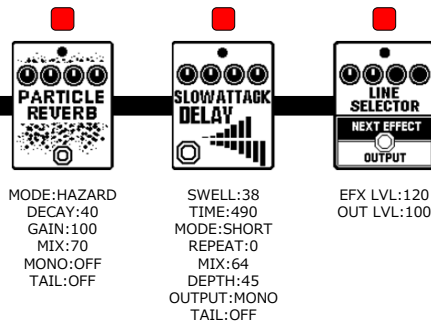

072 : Monument

Based on the Eventide Space TremoloVerb, this sound evokes the atmosphere of a magnificent ruin.

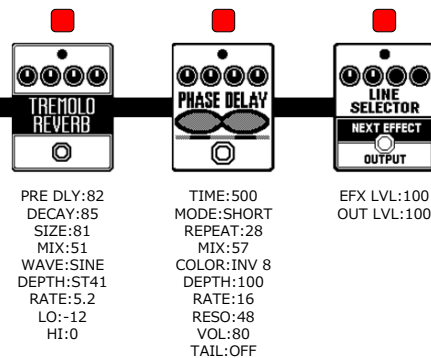

073 : Robot

This mechanical sound combines Bit Crusher and Ring Modulator.

 TIME:214 MODE:SHORT REPEAT:25 MIX:50 SAMPLE:1/10 BIT:10 BLEND:81 DAMP:6 FILTER:6 VINYL:D:1	 BIT:16 SAMPLE:18 TONE:4 BAL:37 VOL:80	 SHIFT: 7 TONE:90 WET:46 DRY:72	 FREQ:28 TONE:10 BAL:38 VOL:88	 EFX LVL:100 OUT LVL:100
---	---	---	--	--------------------------------

074 : Magical Warp

This special effect creates a warp sound by combining Warp Phaser and Stomp Delay.

 BPM:140	 TIGHT:50 MODE:ST-2 WET:75 DRY:75	 TIME:2TH 3 MODE:BPM SYNC REPEAT:55 MIX:48 OUTPUT:MONO HI-DMP:5 TAIL:OFF	 MODE:GO SPEED:8TH RESO:7 VOL:80	 EFX LVL:56 OUT LVL:100
-------------	---	--	--	-------------------------------

075 : Adamski

This nostalgic future sound is inspired by an Adamski-style UFO attack.

 PRE DLY:191 DECAY:20 SIZE:53 MIX:26 CLIP:36 DEPTH:81 LO:2 HI:-1 VOL:61	 TIME:223 MODE:SHORT REPEAT:87 MIX:53 LINK:DLY-PAN CYCLE:17 WIDTH:L30 DEPTH:7 CLIP:0 VOL:80	 DEPTH:90 SPEED:84 TONE:75 MIX:65 DRY:OFF	 EFX LVL:100 OUT LVL:100
--	---	--	--------------------------------

076 : Ring Noise

This noisy ring modulation sound generates a sense of musical intervals.

 160Hz:-1.0 400Hz:5.0 800Hz:0.0 3.2kHz:3.0 6.4kHz:3.0 12kHz:1.0 VOL:85	 TIME:2 MODE:SHORT REPEAT:0 MIX:87 SAMPLE:1/64 BIT:7 BLEND:76 DAMP:8 FILTER:6 VINYL:OFF	 EFX LVL:100 OUT LVL:100
---	---	--------------------------------

077 : Ducking

This sound incorporates an effect that changes how it is applied according to the input volume.

Dynamic Reverb: PRE DLY:0, DECAY:87, SENSE:72, MIX:50, COLOR:76, TAIL:OFF

Dynamic Flanger: SENSE:-10, DEPTH:26, RATE:31, RESO:5, VOL:80

Dynamic Delay: TIME:437, MODE:SHORT, REPEAT:26, MIX:77, SENSE:-10, VOL:80, TAIL:OFF

Line Selector: EFX LVL:65, OUT LVL:100

078 : Eraserhead

Combining models of a Strymon TimeLine ICE and an Eventide Space Blackhole, the sound is like having an inexplicable dream.

Space Hole Reverb: PRE DLY:99, DECAY:-64, REPEAT:25, MIX:46, DEPTH:72, SPEED:42, LOW:-32, HIGH:-59, SIZE:70

ICE Delay: INTVL:-0.5, TIME:500, MODE:SHORT, REPEAT:74, MIX:60, BLEND:13, SMEAR:14, DAMP:8, HPF:60, SLICE:LONG

Line Selector: EFX LVL:100, OUT LVL:100

079 : Sound EFX

This special effect sound for guitar adds an octave below to a Shimmer Reverb.

Shimmer Reverb: PRE DLY:1, DECAY:95, MIX:80, TAIL:OFF, LO-DMP:51, HI-DMP:91

Polyphonic Pitch Shifter: SHIFT:-12, TONE:60, WET:25, DRY:80

Line Selector: EFX LVL:100, OUT LVL:100

080 : Bomber+

This explosive sound combines Bomber with delay and reverb.

Church Reverb: PRE DLY:96, DECAY:83, TONE:41, MIX:43, HIDMP:86, DRY:ON, TAIL:OFF

Dual Reverb: PRE DLY A:350, PRE DLY B:700, A-B MIX:A4B9, MIX:30, DECAY A:48, DECAY B:63, TONE A:0, TONE B:-30, SIZE:A4B9

Stereo Delay: TIME L:1060, TIME R:1000, MODE:LONG, MIX:24, REP L:64, REP R:65, VOL L:100, VOL R:100, VOL:80, TAIL:OFF

Multi Tap Delay: TIME:3000, MODE:LONG, PTRN:2, MIX:100, TONE:4, VOL:80, TAIL:OFF

Bomber: DECAY:50, TONE:4, MIX:30, TRGGR:INPUT



ZOOM CORPORATION

4-4-3 Kanda-surugadai, Chiyoda-ku, Tokyo 101-0062 Japan
zoomcorp.com

Z2I-5218-01